

***OHIO VALLEY MINE
RESCUE CONTEST
TRI-STATE POST # 6
JUNE 6, 2019
DAY # 2 CONTEST***

Statement

Welcome to Bill's mine, my name is Bill and I am the owner and operator of this mine. This is our problem as best as I can explain it.

Today during the shift change from Day Shift to Afternoon Shift I had two men stay on the section to clean and dust. The men called out and said that they had smoke on the section and did not know where it was coming from. One miner said that he was going to find a way out while the other was too afraid to leave the section. We have not heard from them since. We have a three entry section which we are setting up to drive a set of mains off of. The section does generate a good bit of gas and we have hit some old works in the past that were unmapped.

The power is off and the fan is running with fresh air coming up #3 entry across the fresh air base and out the #1 entry. A previous mine rescue team has erected stoppings just inby the Fresh Air Base across #1, #2, & #3 entries to prevent air migration. The mine has a history of bad top. The roof is supported with six foot bolts and all agencies are on hand to assist you and back up teams are on hand. The command center is located on the surface.

Instructions to the Team

“Problem”

Locate all missing miners and bring all survivors to the surface

The exhausting fan is running and cannot be reversed if the team wants the fan stopped they must verbally request the fan to be stopped to the superintendent at the fresh air base and they must verbally request it to be turned back on to the superintendent at the fresh air base

Power is off in the mine and will not be re-energized

Barricades can be torn down for ventilation if they are needed to be used to ventilate the mine but only with the superintendent’s verbal permission.

If you need to use the barricade for ventilation just tell the judge on the field, you want to use the barricade for ventilation and a curtain will be provided to the team on the field to use do not move the existing barricade just leave it open or down to indicate it is not in use.

There will be a 65-minute time limit on the working of the problem with a 10-minute warning given to the team.

Blank Map

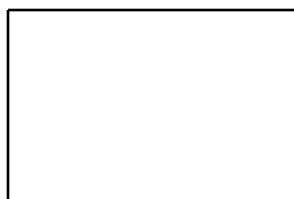
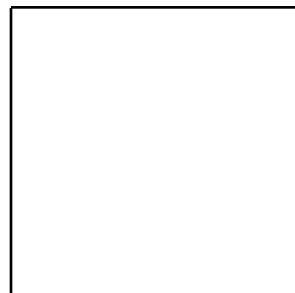
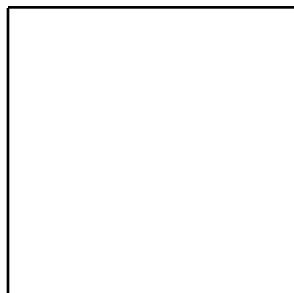
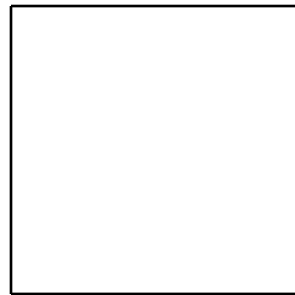
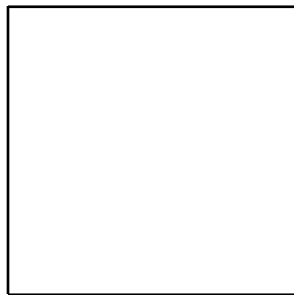
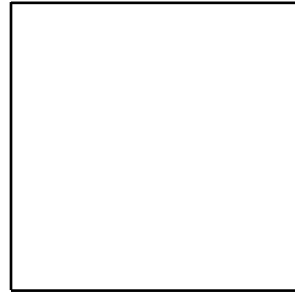
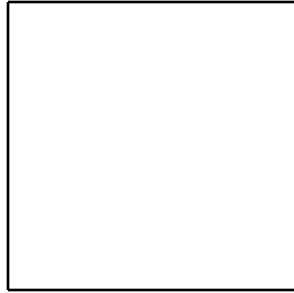

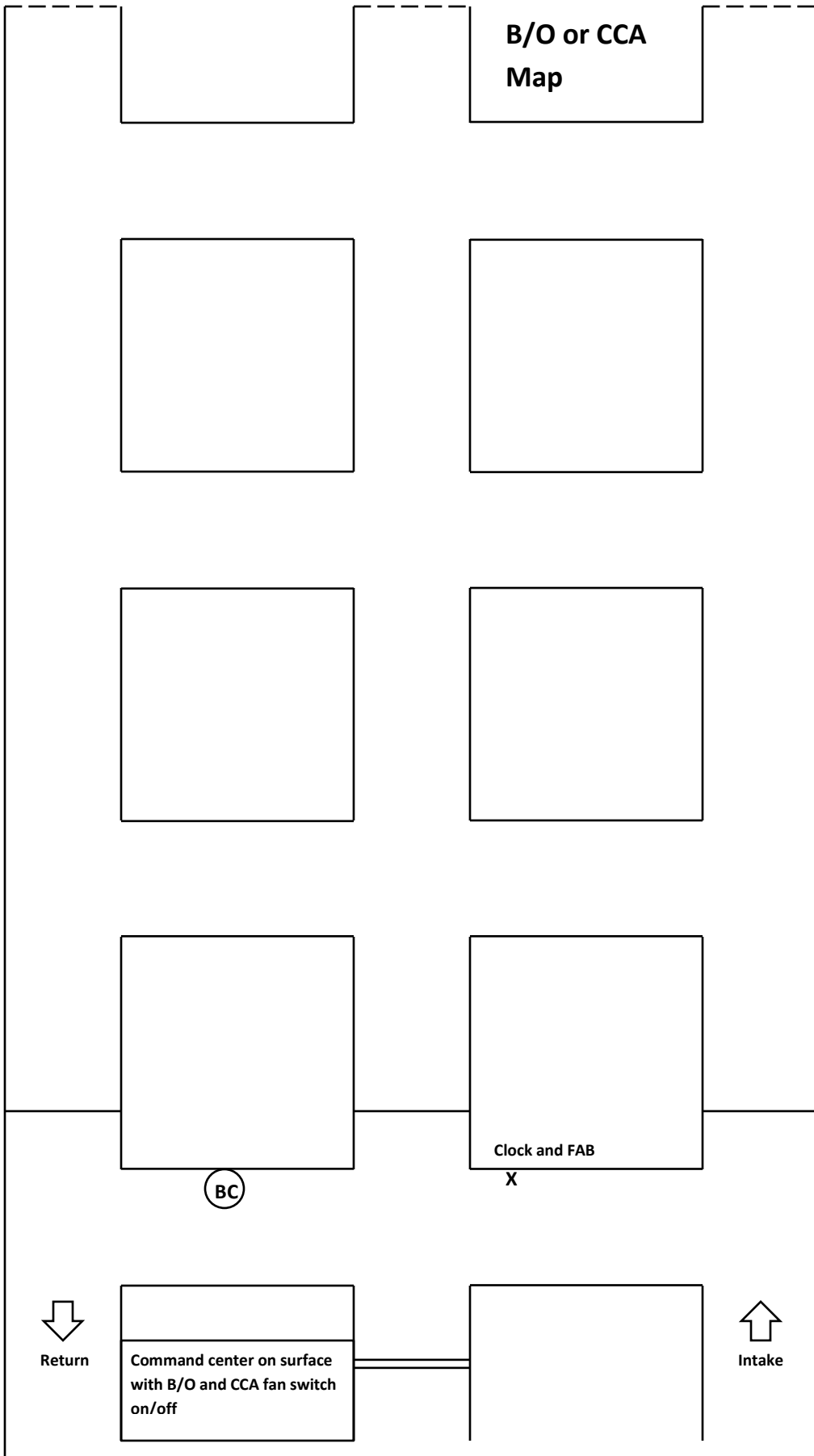

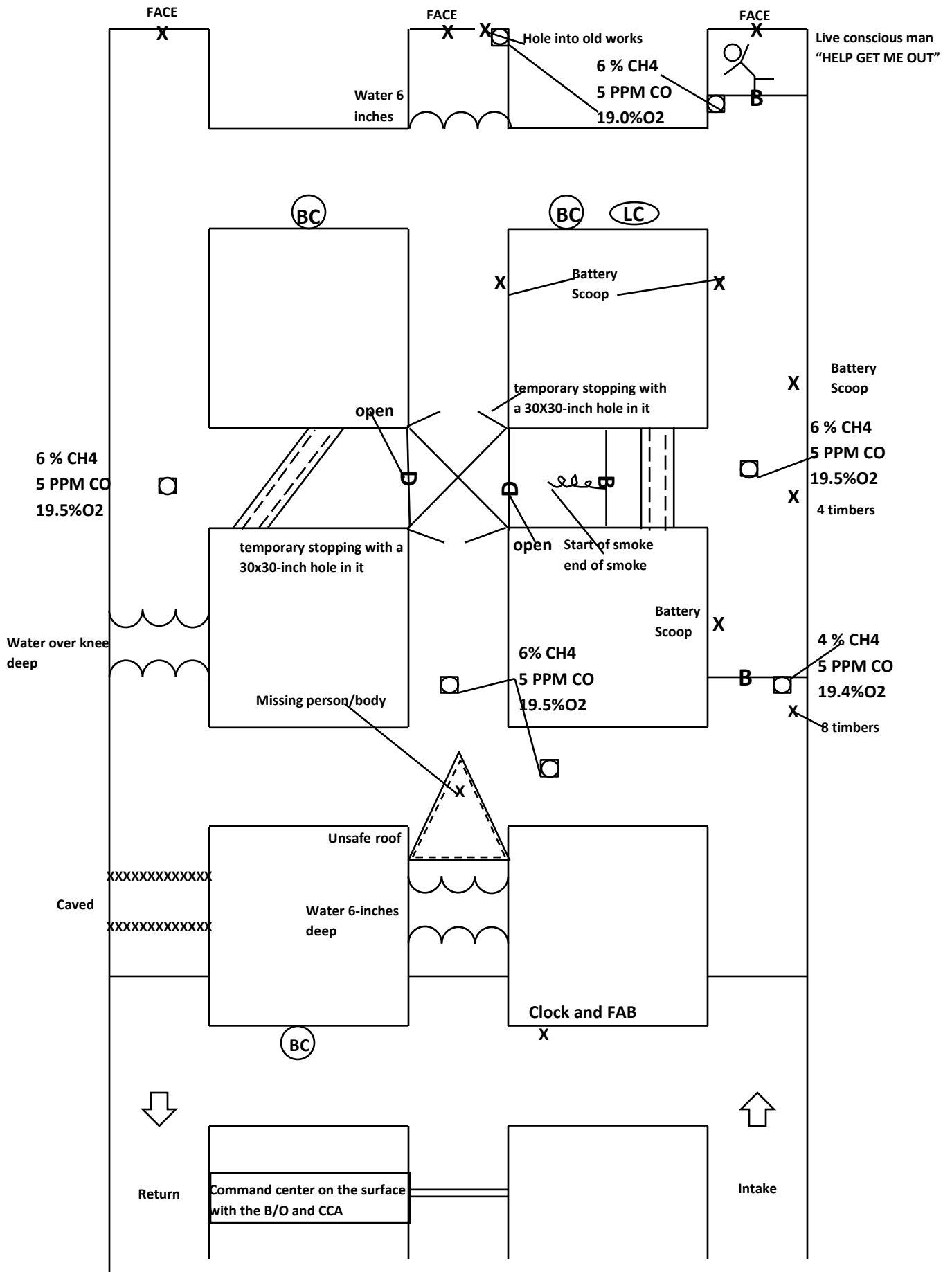

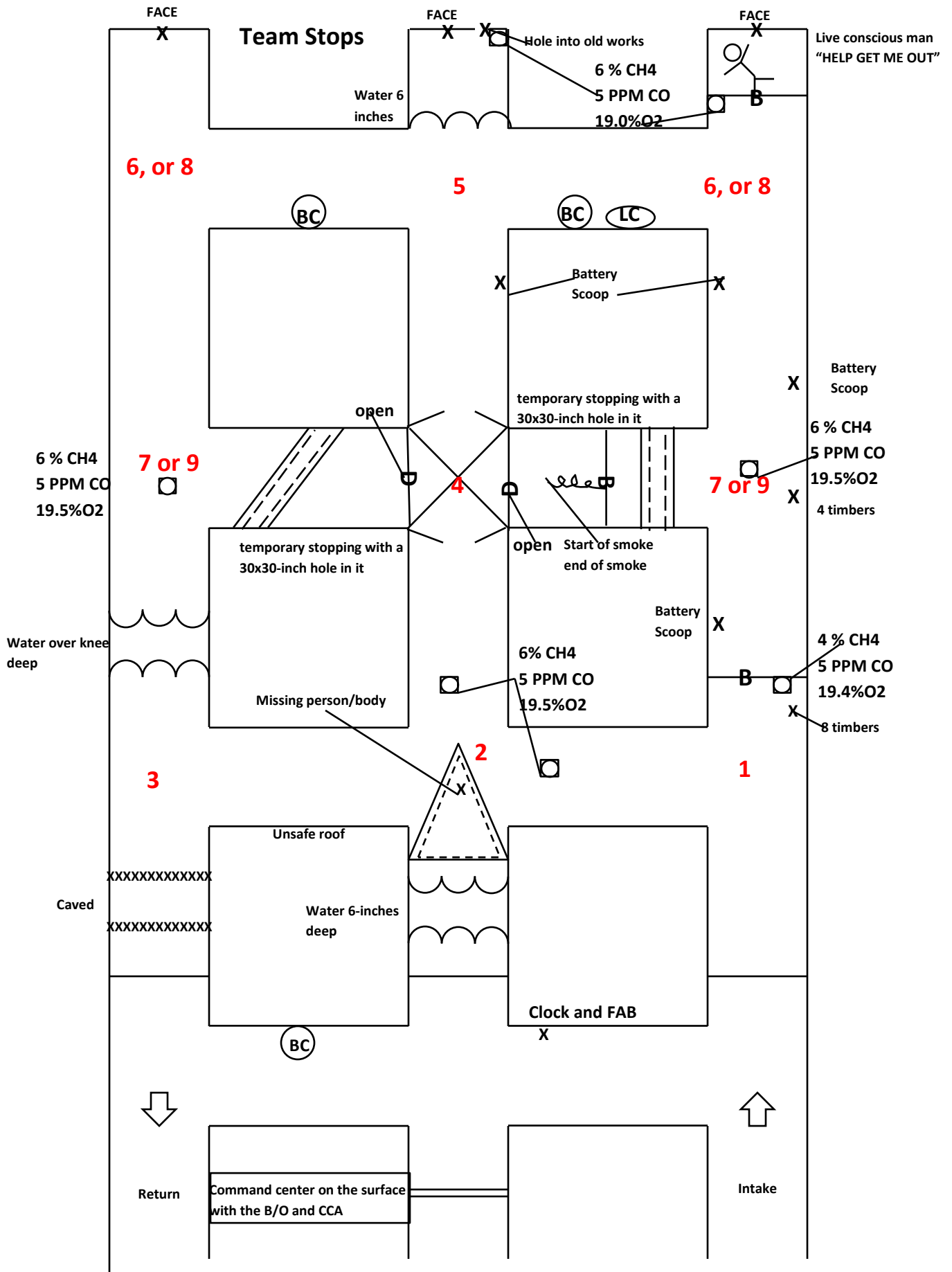

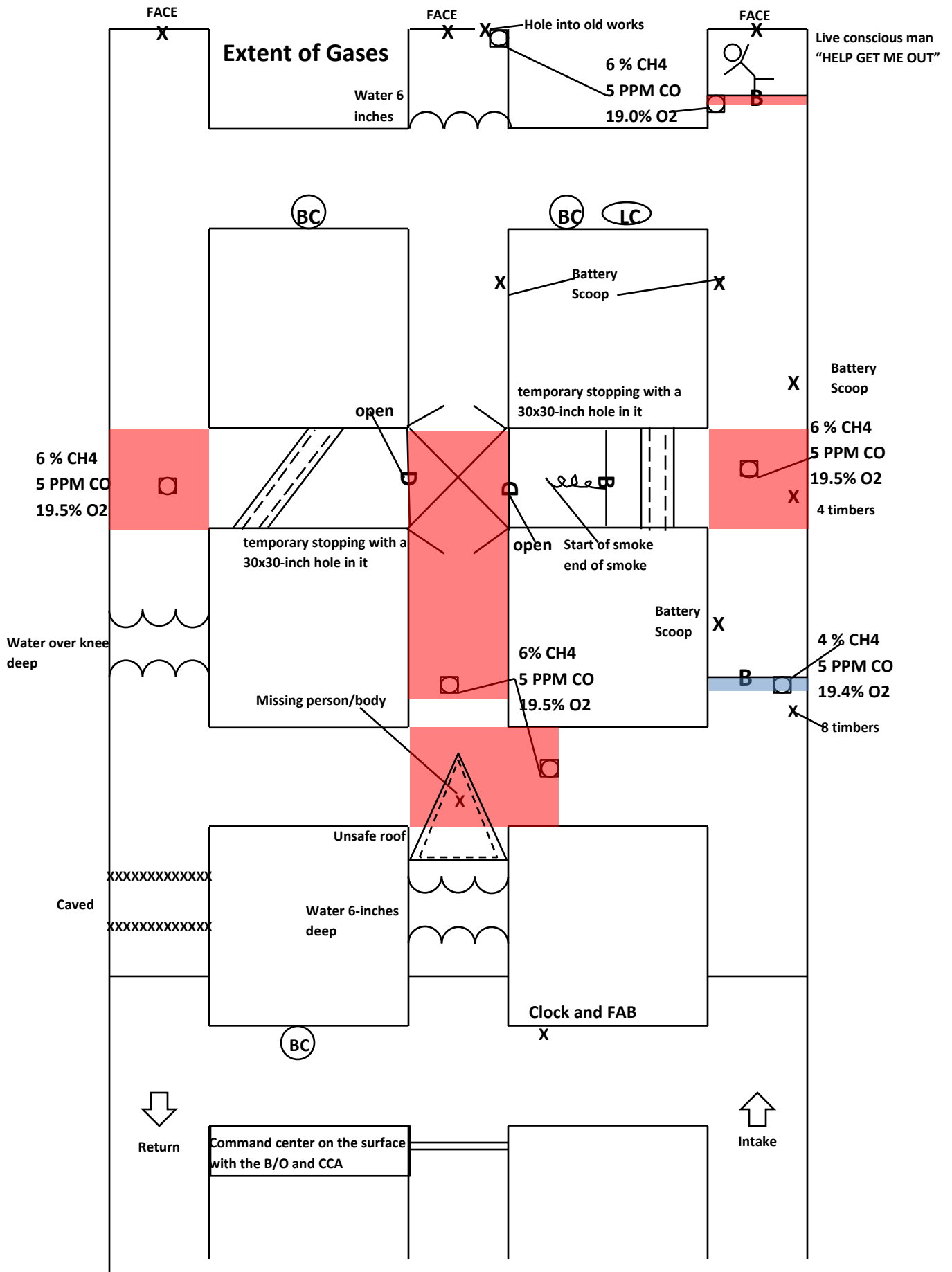

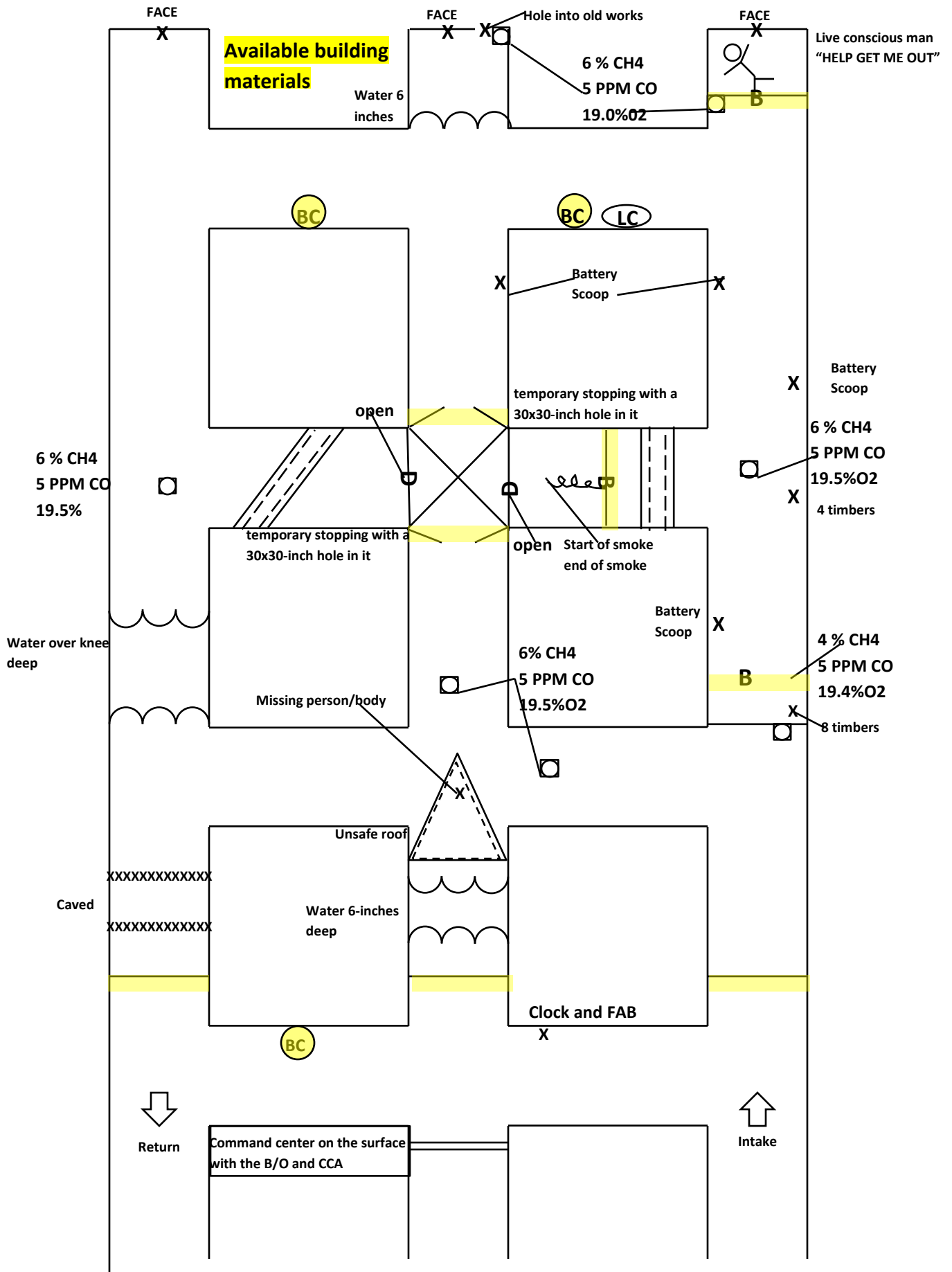

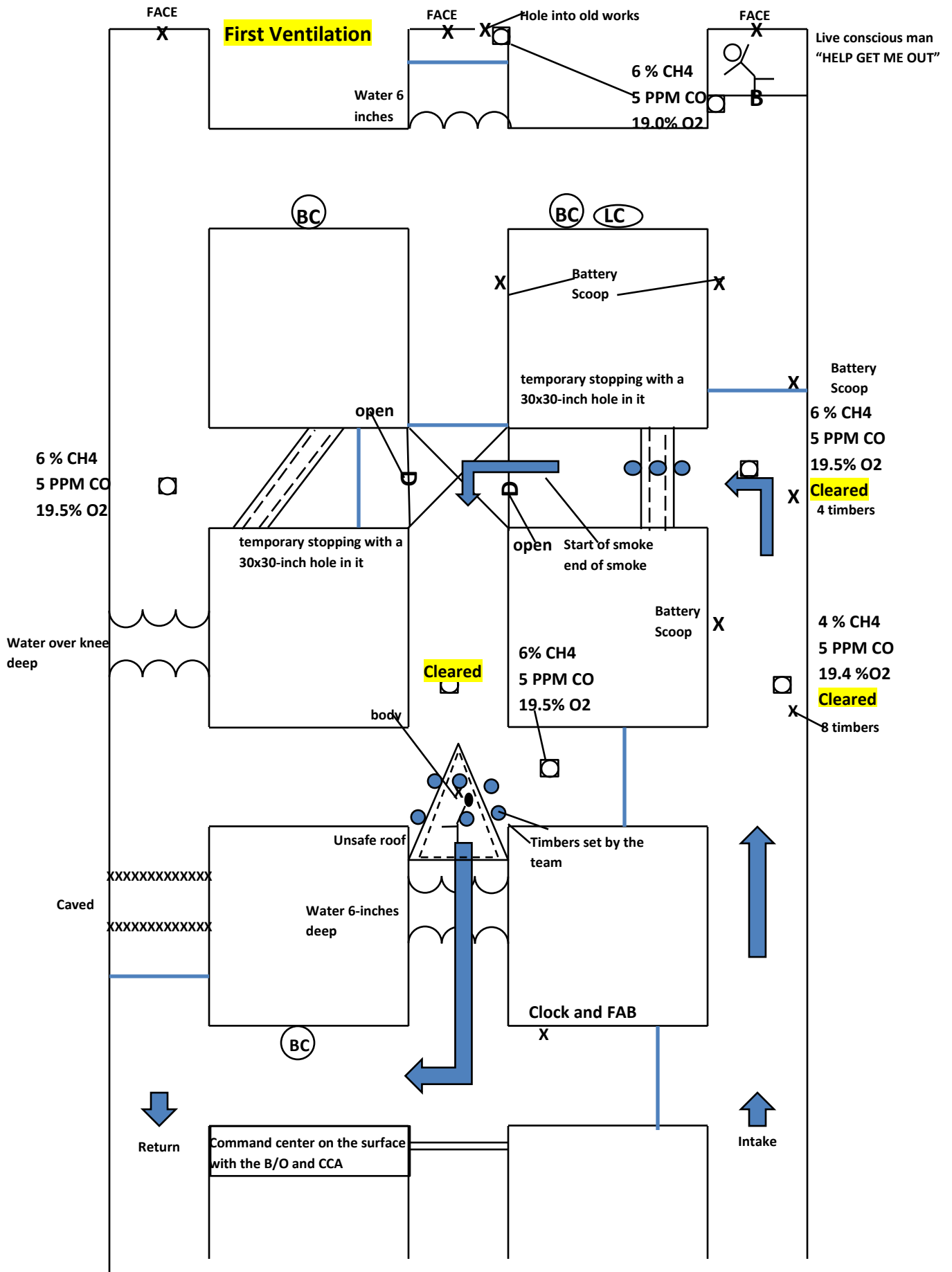

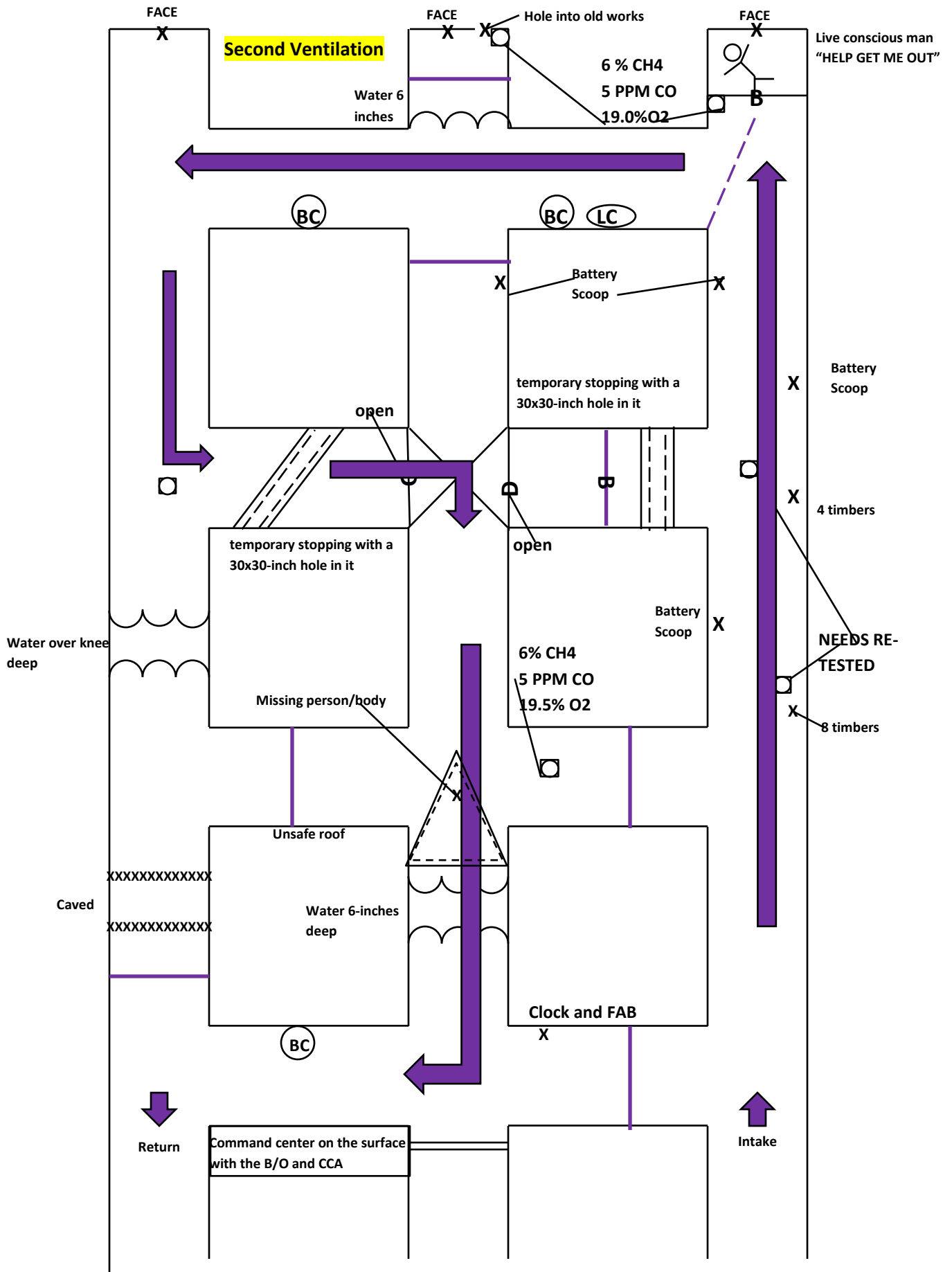

**Possible Timbering
Scenario #1 Detail "A"**

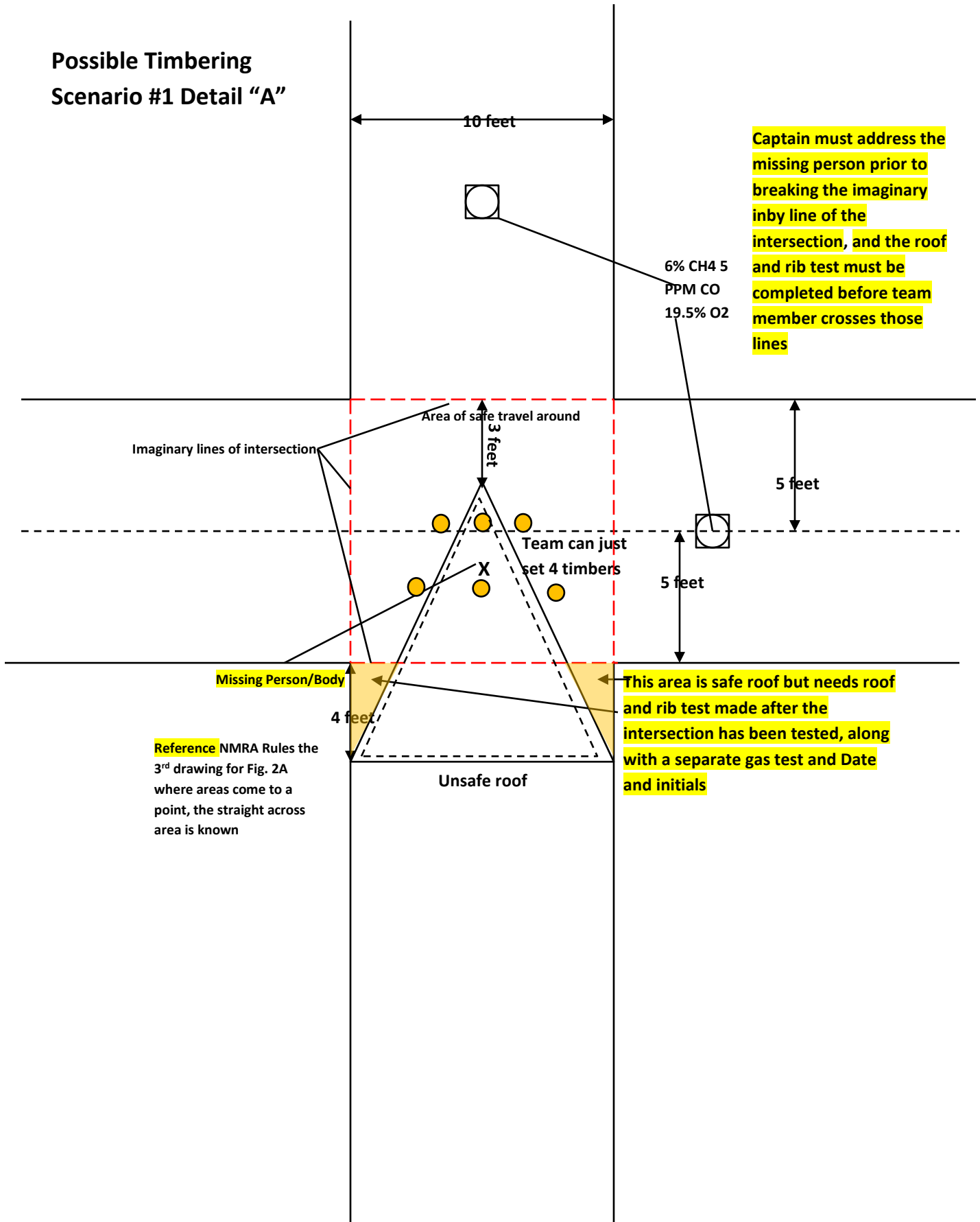

Reference NMRA Rules the 3rd drawing for Fig. 2A where areas come to a point, the straight across area is known

Captain must address the missing person prior to breaking the imaginary inby line of the intersection, and the roof and rib test must be completed before team member crosses those lines

This area is safe roof but needs roof and rib test made after the intersection has been tested, along with a separate gas test and Date and initials

Detail "B" Roof and Rib Test

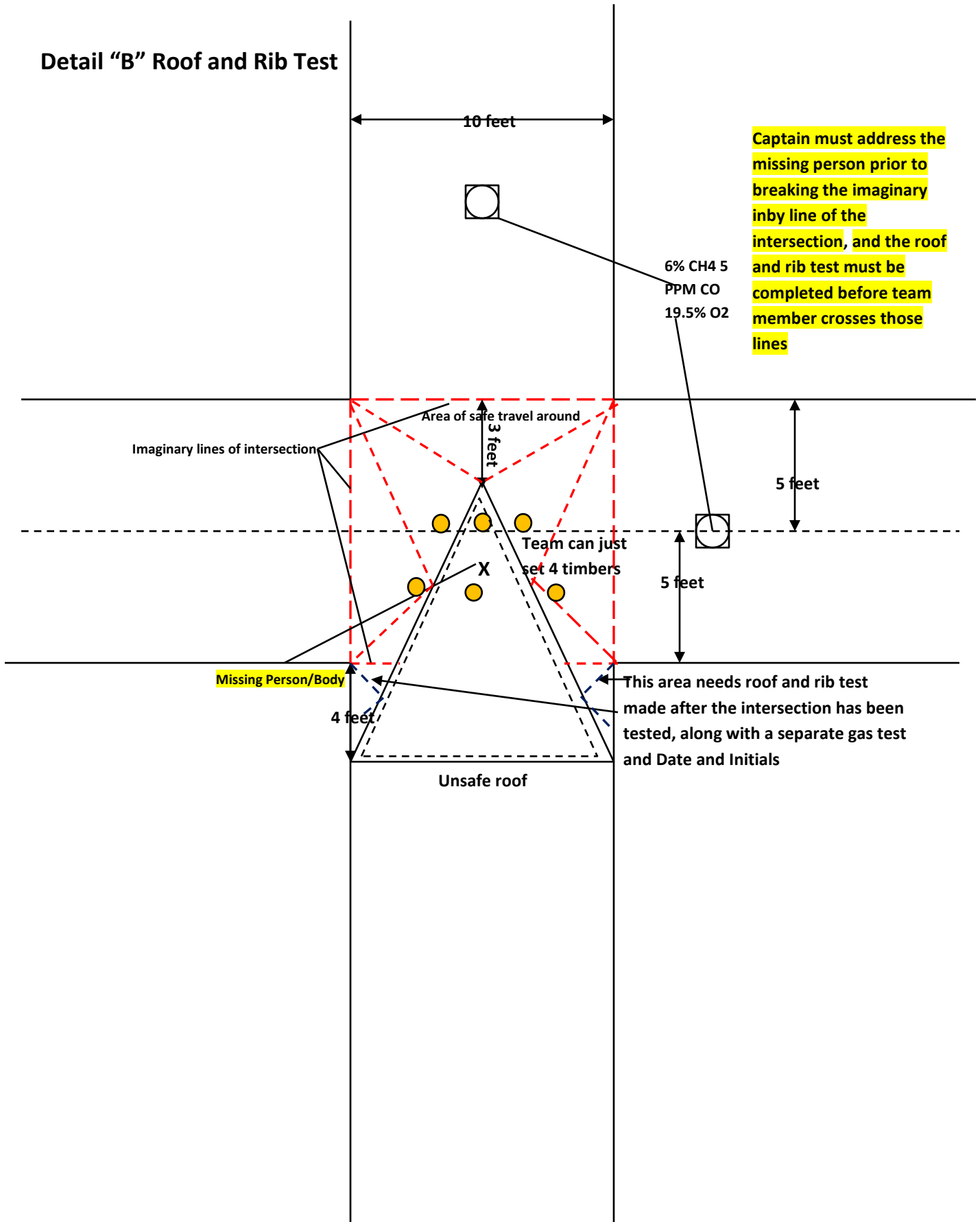

Judges Instructions

From the Fresh Air Base, the team will examine the portals and find a stopping across #1, #2, #3 entries. Teams will use the brattice material in the fresh air base to airlock into #1 entry and find a caved across the entry. In # 2 when they air lock in they find unsafe roof across the entry they will need to perform a roof test up, and Date and initial at the unsafe roof the gas test when breaching the temporary stopping will suffice for the gas test at the unsafe roof. the next entry to be examined is # 3 entry for a portal check yet. **Note that under #24 D when breaching an air tight separation, the captain must take the gas test on the inby side of the stoppings located just inby the Fresh Air Base and under Rule #24 B that test will suffice for the gas test in the opening.** The team then will travel to # 3 entry just inby the portal and airlock through the stopping there and bring the entire team in at that time for the initial pack check.

Team stop #1 will be in A line of #3 entry their reach inby will find a barricade across the entry with a non-explosive/irrespirable gas placard there and no response from inside the barricade. Their reach toward #2 entry in A line finds an explosive gas that extends into the intersection of # 2 entry. In the intersection of # 3 entry of A line the team has found 8 timbers.

Team stop # 2 will be in the intersection in A line of # 2 entry there is a triangular area of unsafe roof in the intersection that extends outby which will make the entire intersection unsafe and requiring a zig zag roof and rib test to be made by the captain **(see Detail Drawing "B")**. There is sufficient space to travel past the peak of the unsafe roof allowing all sides of the triangular area of unsafe roof to be examined by the captain. There is a missing person under the unsafe roof that under Rule #29 requires immediate action to be taken. Since there are 8 timbers available to use the team should use them to timber through the unsafe roof in the intersection to get to the missing person **(see Detail Drawing A and B)**. Since under Rule #29 paragraph #4 when the captain enters the intersection all conditions are known. Once timbered into the missing person as to address the missing person under Rule #32 which is the captain's touch by hand and under Rule #23 the captains date and initials then that placard, (missing person) will become a body. Now that the captain has addressed the body he may perform a roof and rib, gas test, and date and initials in the two small triangular areas outby the intersection past the imaginary lines, **(see Detail A or B)**, however he may choose to check the inby area or outby area first which is fine as long as all accessible areas are checked before leaving this team stop. These areas must have a separate roof and rib test made after the intersection has been tested and date and initials under Rule #23, date and initials #27, and a gas test under Rule #24. Also now that the intersection has been completed the captain may now take his required 25 ft. reach toward # 1 entry in A line and inby the intersection in #2 entry. Inby they find an explosive air gas mixture in direction of travel and at the end of their reach a temporary stopping with a 30-inch x 30-inch hole in it.

Team stop #3 will be in A line of #1 entry where the team finds a caved area outby requiring a roof and rib test, gas test and date and initials. Inby the intersection the team finds water over knee deep inby requiring a gas test and date and initials.

Team stop #4 will be in B line of #2 entry where the team passes through the 30" x 30" hole in the temporary stopping into the intersection. In the intersection the team is under an overcast with doors open on both sides and another temporary stopping with a 30" x 30" hole in it also. Gas test are required at the overcast walls, (Rule 24 A) and then inby the temporary stopping just past the imaginary line for the opening along with a gas test in the opening pass the doors in the overcast walls. Dates and initials are required on just one side of the overcast walls and stoppings. Inby the intersection the team finds a battery scoop in #2 entry in the cross cut toward # 1 they find unsafe roof across the entry diagonally. In the cross cut toward # 3 they encounter smoke which will require the team to hold onto the link line and the # 5 man is in air clear, a brattice build and a barricade from behind which there is no response.

Team stop #5 will be in C line of #2 entry, from the intersection in C line of #2 entry a gas test is required in all openings of the intersection. Their reach toward the face finds a face partially across the entry with another placard stating "Holed into old works" and an explosive air gas mixture side by side on the side of the entry. The face requires a roof, face and rib test, gas test, & date and initials be made under Rules #23, #24, and #27. The holed into old works requires a separate gas test. The team reaching toward #1 entry finds a brattice build that they will probably use to seal off the face of #2 entry. In the cross cut toward #3 entry they team finds nothing. It is now the team's choice which way to go.

Team stop #6 can be in # 1 entry or in #3 entry in C line. If they go to #1 first there should be gas tests made in all openings of the intersection. Inby they find a face requiring a roof, face, and rib test, gas test, and date and initials and outby nothing.

Team stop #7 if they went to #1 entry first it should be in B line of # 1 entry where the team finds an explosive air gas mixture. In the cross cut toward #2 entry they find diagonal unsafe roof across the entry and outby they find water over knee deep across the entry.

Team stop #8 if the team went to #1 entry first they will need then to travel back to C line of #3 entry where inby the intersection they find a barricade with a response from behind it,(Help get me out) and an irrespirable in front of it, outby they find two battery scoops.

Team stop #9 if they went to #1 entry first, will be in B line of #3 entry. Where the team finds an explosive gas mixture in the intersection and 4 timbers, with gas test required in all openings of the intersection. Outby the intersection the team will tie the back side of the Barricade that they found at Team stop 1 and yet another battery scoop. In the cross cut toward #2 entry there is unsafe roof across the entry requiring a roof and rib test, a gas test that can suffice for the opening gas test, and date and initials. The team may choose at this

time to timber through the area of unsafe roof toward #2 entry. If they do, they will find the back side of the unsafe roof which requires a roof and rib test to be made prior to team members passing through it and the backside of the barricade which requires a date and initial. **At this time the team has means to ventilate the inby barricade. Please refer to ventilation drawings step #1 and #2.**

Now if Team stop #6 is in #3 entry of C line then the reverse order would be described for the last three team stops.