

**2019 Post 5
Day 2**

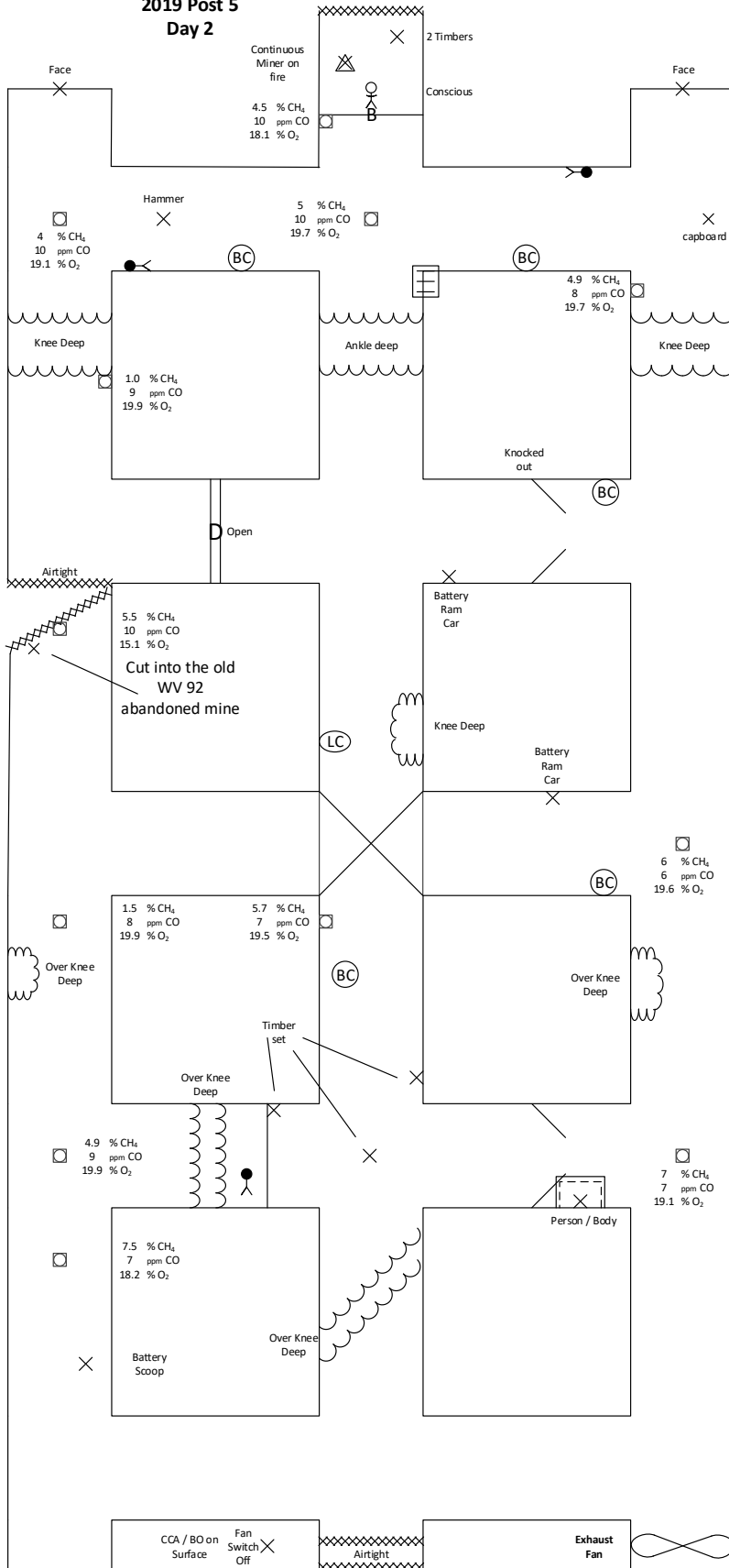

2019 Post 5

Day 2 Statement

You are located underground in the first crosscut of the Old WV 93 mine. A fresh air base has been established here after the dispatcher could not contact the five man crew that was working on equipment in preparation for coal production in the near future at this mine.

The dispatcher said she felt her office trailer shake and then shortly after the fan stopped running. We have had no further contact with the miners and decided to call you and your team. The Old WV 93 is being reopened after several years of being idle. This mine was driving in between the abandoned WV 92 and WV 94 mines when adverse conditions and a bad coal market halted operations.

Also, we've had lots of trouble with a contract engineering company not doing correct maps and believe our maps may be a little bit off. So, the mine maps you will be given are not up to date. All authorities have been notified and a backup team is here. Please be careful during your exploration and thank you for your help...

Team Instructions

- **The exhaust fan is off**
- **The exhaust fan cannot be reversed**
- **The fan can be turned on and off by a fan switch located in the Command Center station**
- **When turned on, the fan cannot be stalled during operation**
- **Account for all missing miners and bring survivors to the fresh air base**
- **The Command Center Attendant and/or Briefing officer is on the surface**

Team Map

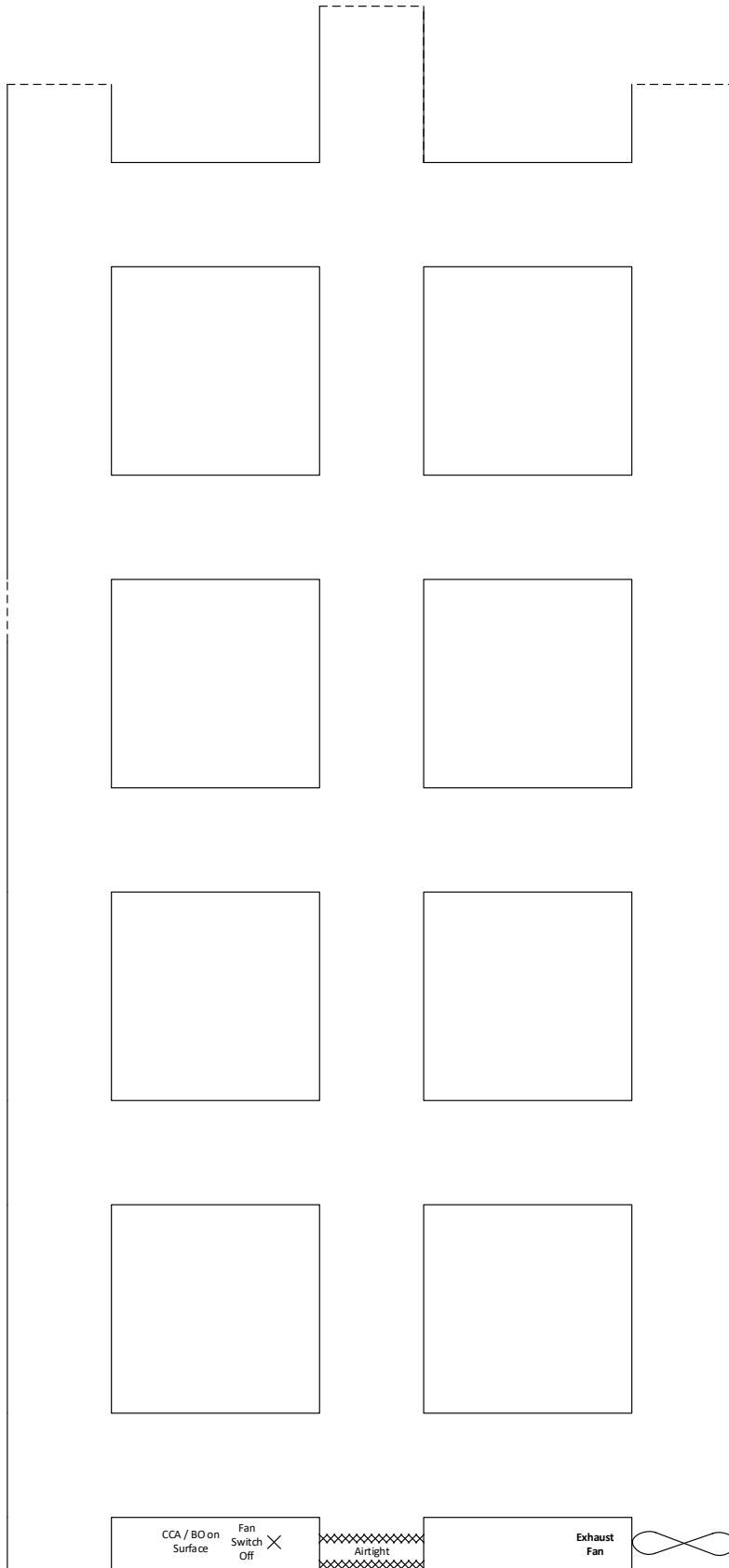

**2019 Post 5
Day 2**

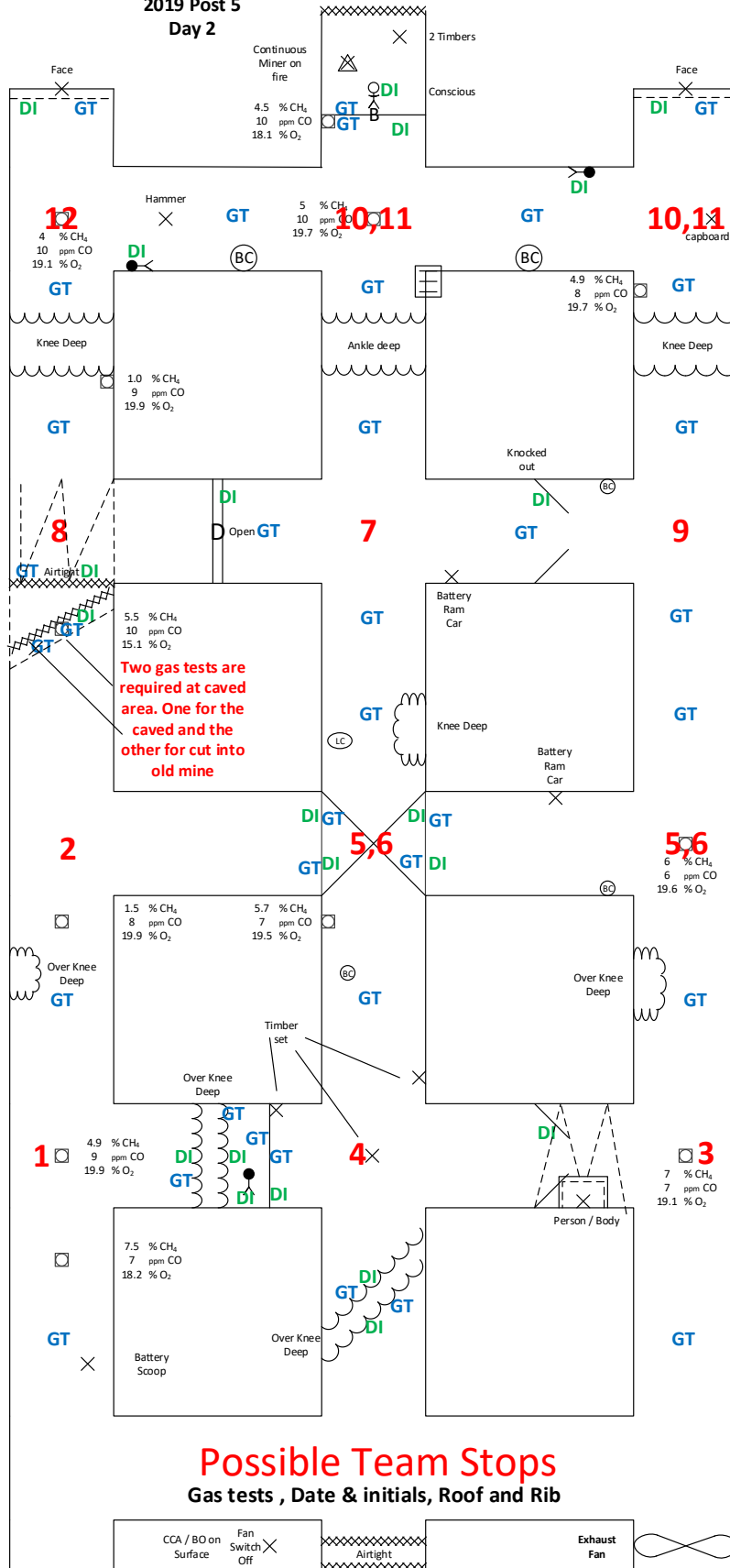

Possible Team Stops

Gas tests , Date & initials, Roof and Rib

Team Stop No. 1

(See Team Stop Map)

Team must travel to no.1 entry first intersection

Team Stop No. 2

Team can travel in the no. 1 entry to the 2nd intersection **OR** team can travel to no. 3 entry 1st intersection.

Team Stop No. 3

Team can travel to no. 3 entry to first intersection

Team Stop No. 4

Team will tie across to the first intersection in no. 2 entry

Team Stop No. 5, 6

Team has options because of finding contaminates being in no. 1 and no. 2 entry

Team Stop No. 7

Team must travel in no. 2 entry to the 3rd intersection because of explosive mixture going into caved area of no. 1 entry

Team Stop No. 8

Team must travel to no. 1 entry 3rd intersection because of explosive mixture going into caved area of no. 1 entry

Team Stop No. 9

Team will tie across to no. 3 entry 3rd intersection

Team Stop No. 10, 11

Team must travel in the no.2 or no. 3 entry in 4th intersection because of contaminate found in no.3 entry. If travel in no. 2 entry Patient behind barricade will say "Help, Get Me Out"

Team Stop No. 12

Team will travel to no. 1 entry 4th intersection (Team cannot delay patient in this problem)

Vent no. 1

See Vent 1 Map

- Team cannot wing barricade from the unsafe rib corner in 4th intersection.
- Do not clear barricade if team hangs wing curtain from unsafe rib corner

Vent no. 2

See Vent 2 Map

- Team will wing barricade with this vent.
- Team must airlock into barricade
- Team must not try to extinguish fire because of explosive mixture going into caved area in the no. 1 entry just inby the 2nd intersection
- If team tries to put out the fire, tell them the fire is **not out** and discount them for trying to extinguish (Rule 31 B)

**2019 Post 5
Day 2**

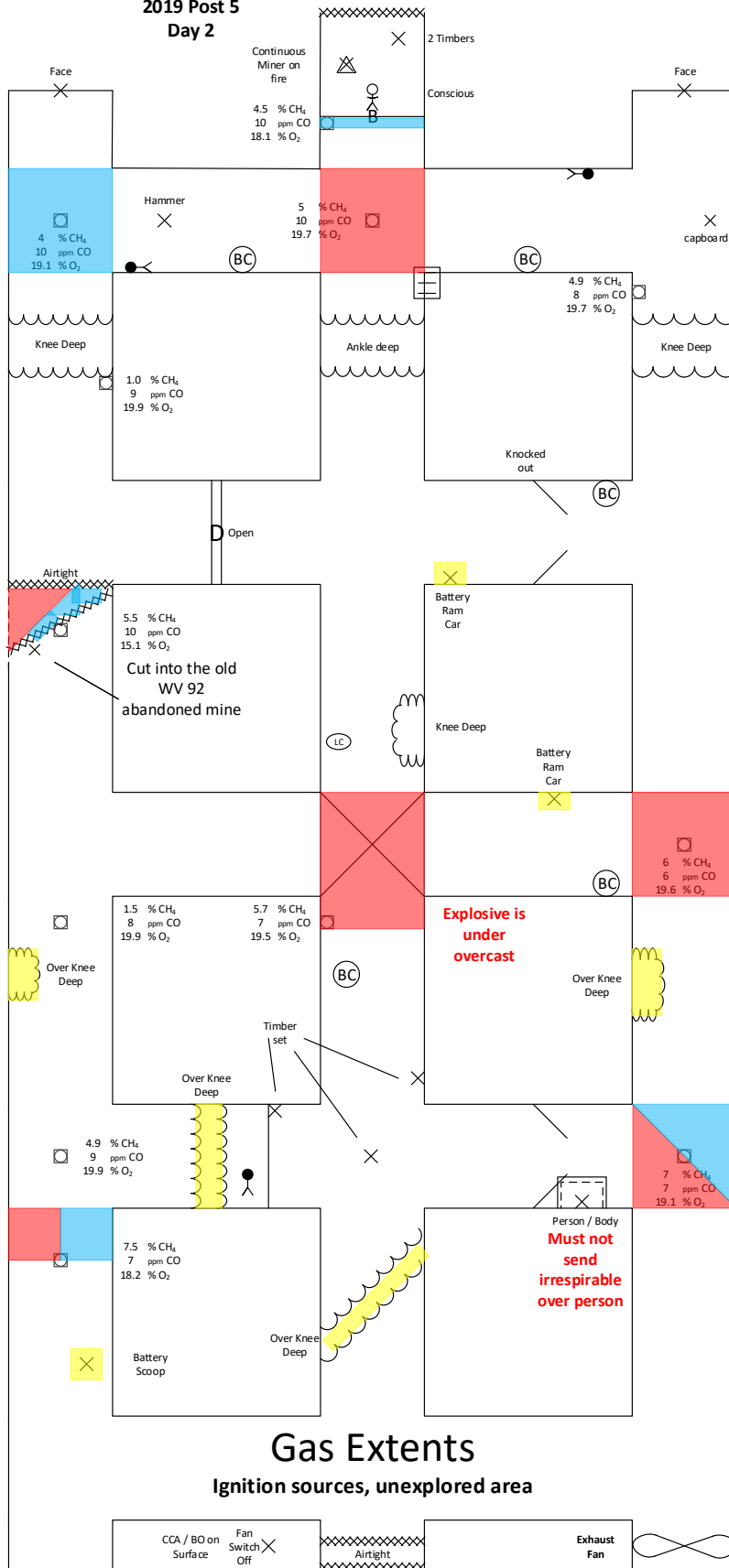

**2019 Post 5
Day 2**

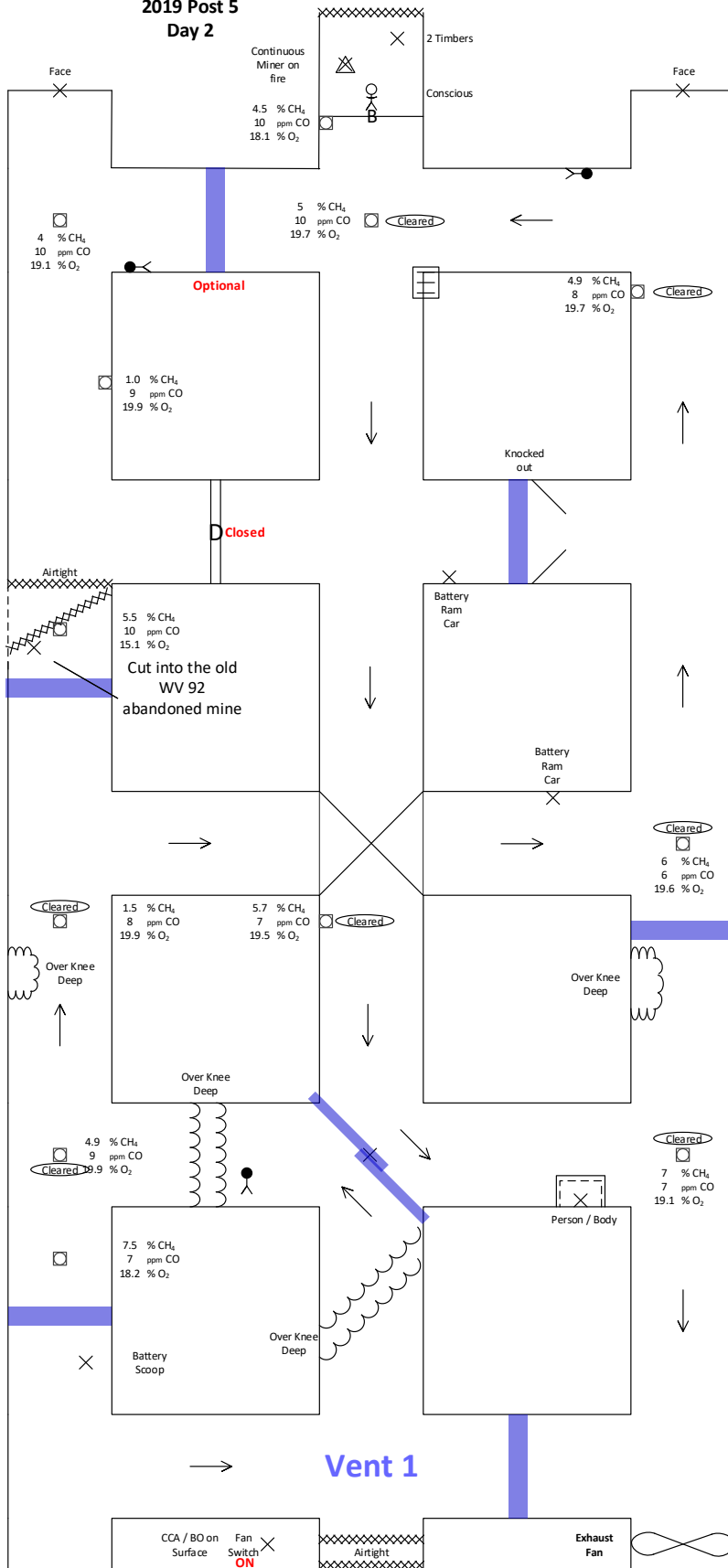

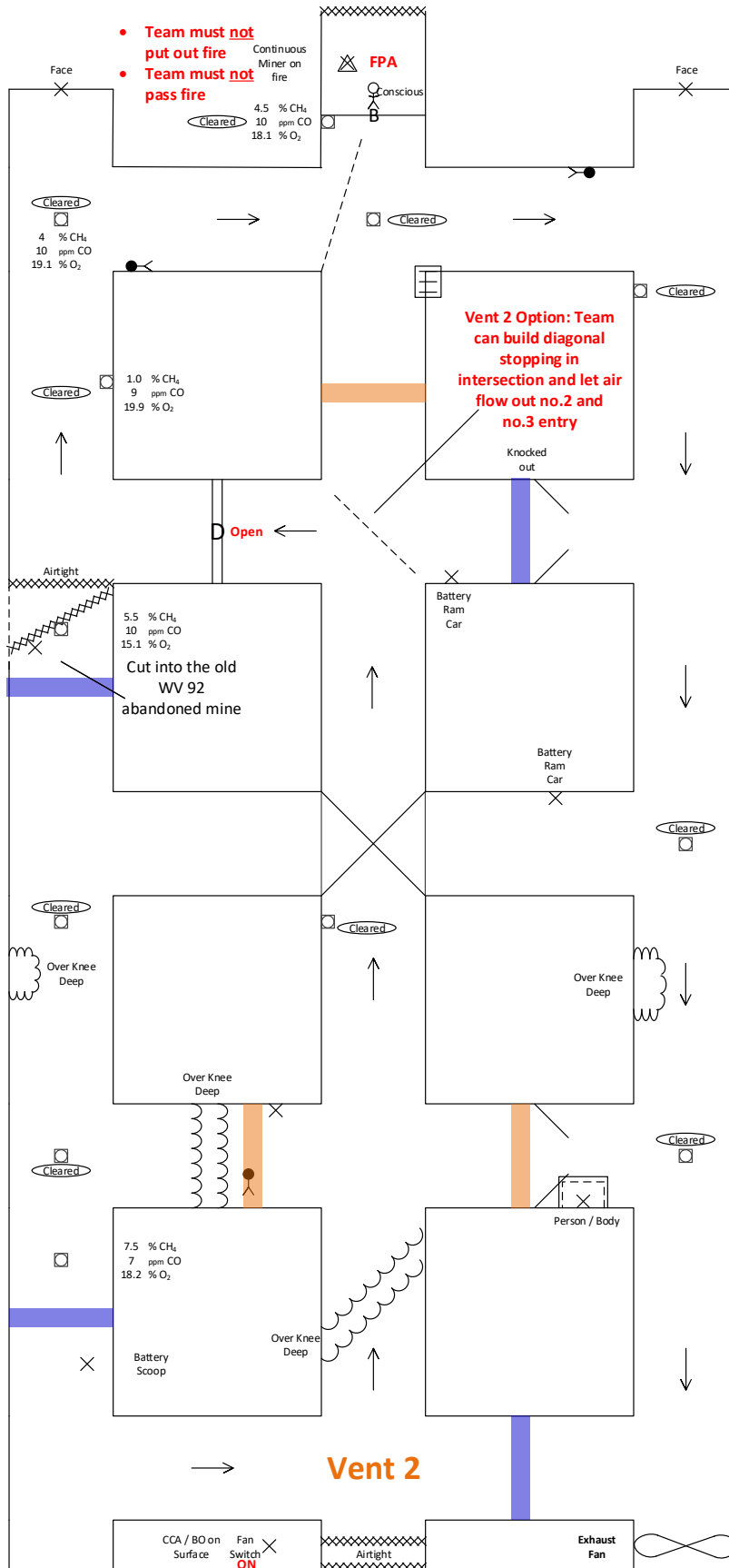

Final Vent Map

