

Statement

Thank you for responding to our call for help I will inform you of the situation as we now know it.

Today we sent a three-man crew to an old section of this mine that has a bleeder to an old mined out pillar line connected to main return air course leading to the exhaust shaft. This mined out area is separated from the air coursing across the bleeder line by three stoppings and there is an evaluation point located there to monitor the area. The crew was to repair those stoppings that had been reported by the fireboss as leaking when he made his exam last night.

At about 11:00am the crew leader called out that they had found smoke in the # 2 entry outby the bleeder line and that he had a man checking it out. He also reported that he had traveled up to the stoppings and found two of the three stoppings down and open to the old pillar line. He said that he had checked the evaluation point with an anemometer and had no air movement at the evaluation point and that the 4ft. X 4ft. door in the evaluation point wall was closed. The crew leader was instructed by the responsible person to remove himself and his crew to a safe place outby there and call out when they were safe. The crew never called out and we have not been able to reach them by radio since then.

We decided to call in the authorities and activated both of our rescue teams to try to locate our people. One team traveled up the return entry from the fan to the backside of the evaluation point where they reported that the evaluation point wall was intact with a large walk through door closed in the wall. Usually the large walk through 4 ft. X 4 ft. door is kept open. The mine's engineer calculates with the 4ft. X 4ft. door open that should be sufficient velocity of air to exceed 15,000 CFM needed to clear any gases in that area.

That team also took a bottle sample of the air at the evaluation point return side and the results of the test showed the air containing 5% CH₄, 9 PPM CO and 13.0% O₂. This team had a pack malfunction at that point and had to retreat from the area, but said the return from the evaluation point to the exhaust shaft was safe and clear to ventilate through. The second team made it to the area where the crew left their mantrip about two cross cuts outby the bleeder line when the first team's pack malfunction so we pulled that team out after they set up a fresh air base since they had no back up team. That team reported no air movement coming up the # 1 and # 3 entries toward the bleeder line and those are the intake entries for the evaluation point. They also took a bottle sample and found the air clear and respirable.

You are to explore inby the fresh air base location where the mantrip was found, and both of our teams are ready as your back up. The exhausting fan is running but cannot be stopped stalled or reversed. The Maps are up to date only to the walls that are separating the pillared out area from the last open to the return. All authorities are on site, the mine is walking height, and accumulations of methane are common in the old works. A minimum air flow of 15,000 CFM must be maintained across the last open cross cut of the bleeder line of the pillared out area to remove any irrespirable or explosive gas accumulation found in the last open or toward the old pillar line.

GOOD LUCK

Problem/Instructions to the Team

Explore the entire mine that can be safely explored, located all missing persons and bring all survivors to the fresh air base

Before any ventilation changes are made the team must request in writing their request and have the Superintendent at the Fresh Air Base give his permission and initial the request

Any unconscious persons found must be placed on a stokes stretcher and carried to the Fresh Air Base

Do not take the evaluation point wall down to relocate it you may open or close doors in it as needed

You will have 60 minutes to work this problem

Ventilation Change Request

1. Ventilation change request: _____ Superintendent: _____

2. Ventilation change request: _____ Superintendent: _____

3. Ventilation change request: _____ Superintendent: _____

4. Ventilation change request: _____ Superintendent: _____

5. Ventilation change request: _____ Superintendent: _____

6. Ventilation change request: _____ Superintendent: _____

7. Ventilation change request: _____ Superintendent: _____

8. Ventilation change request: _____ Superintendent: _____

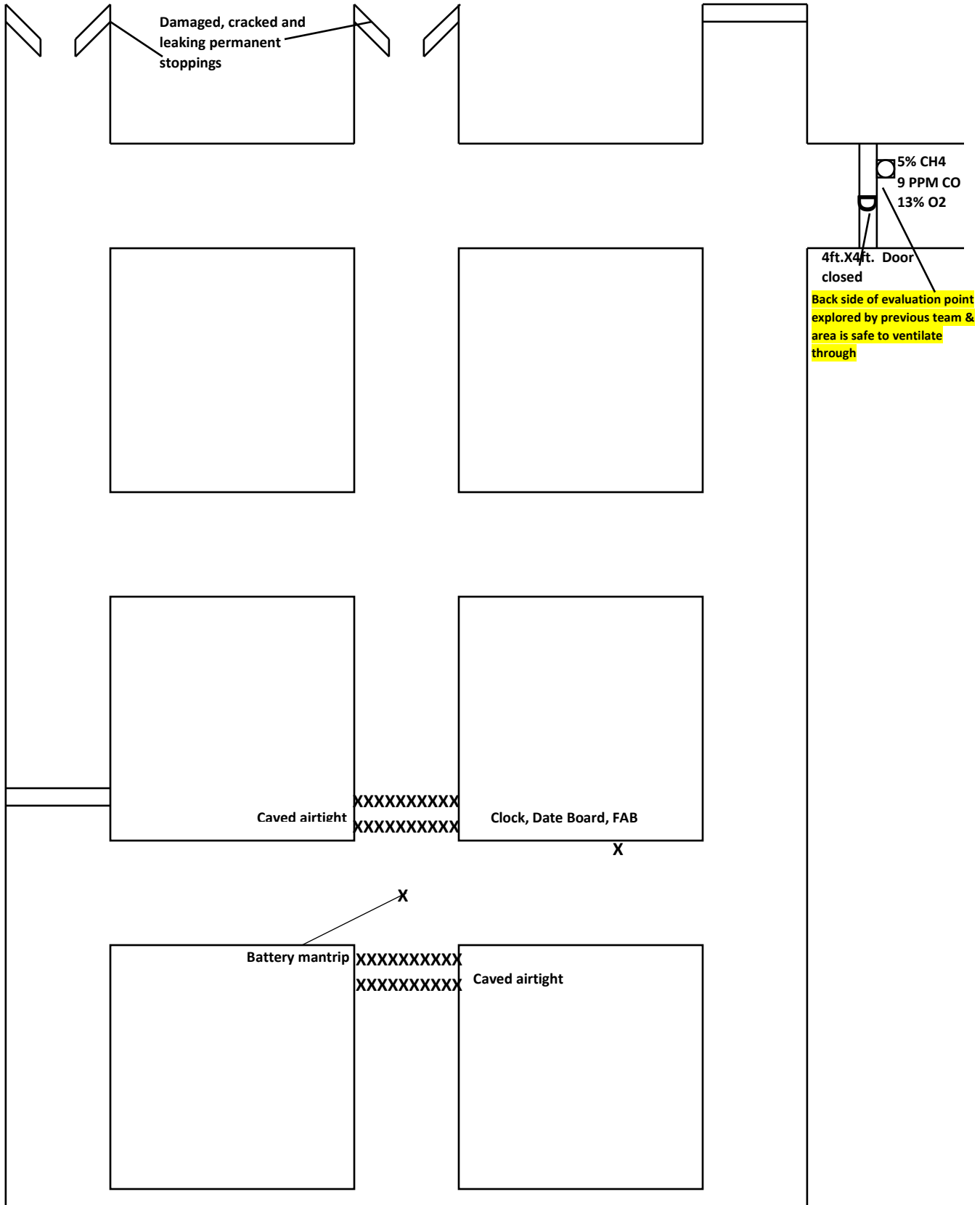

Extent of Gas

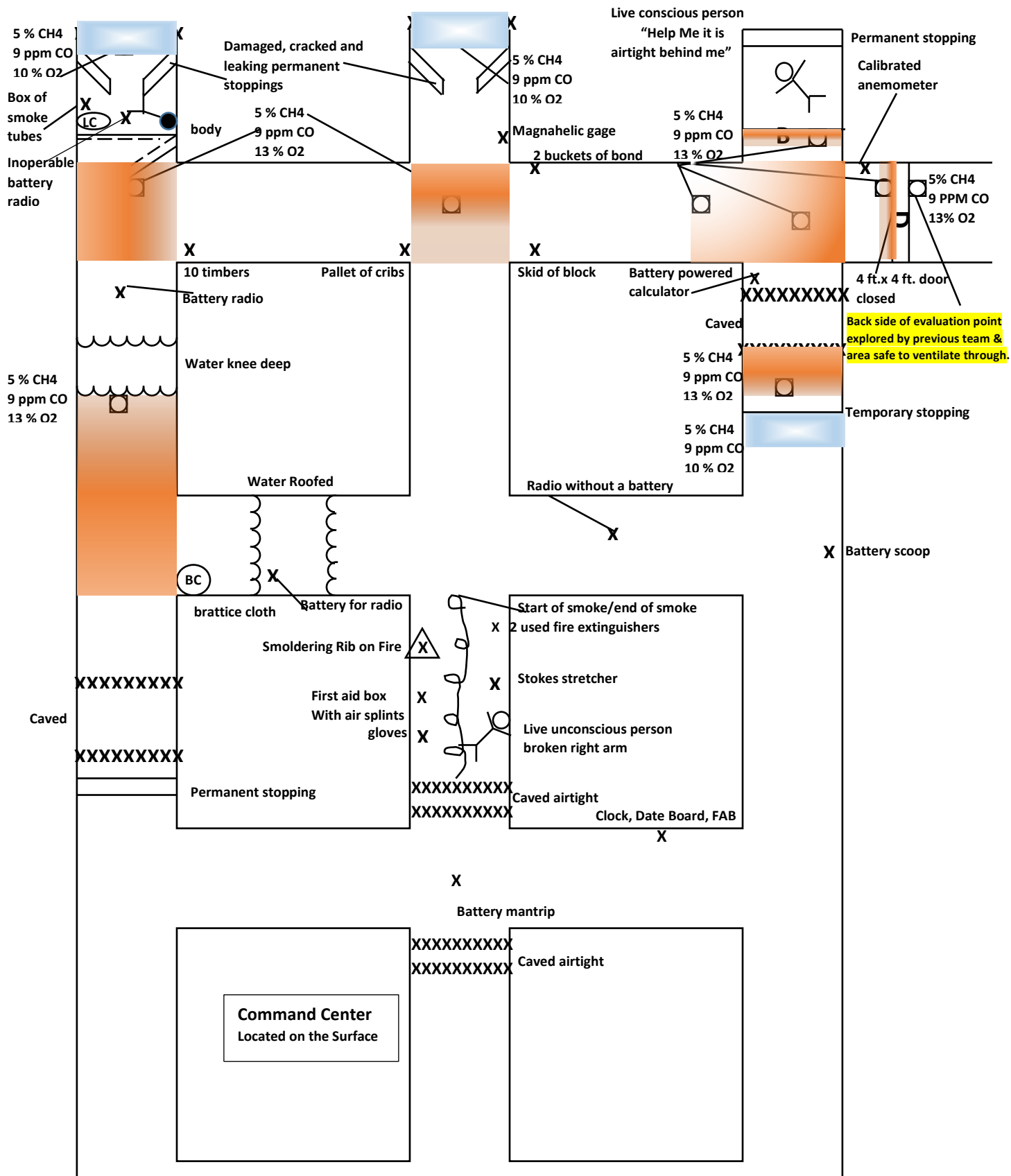

TEAM STOPS

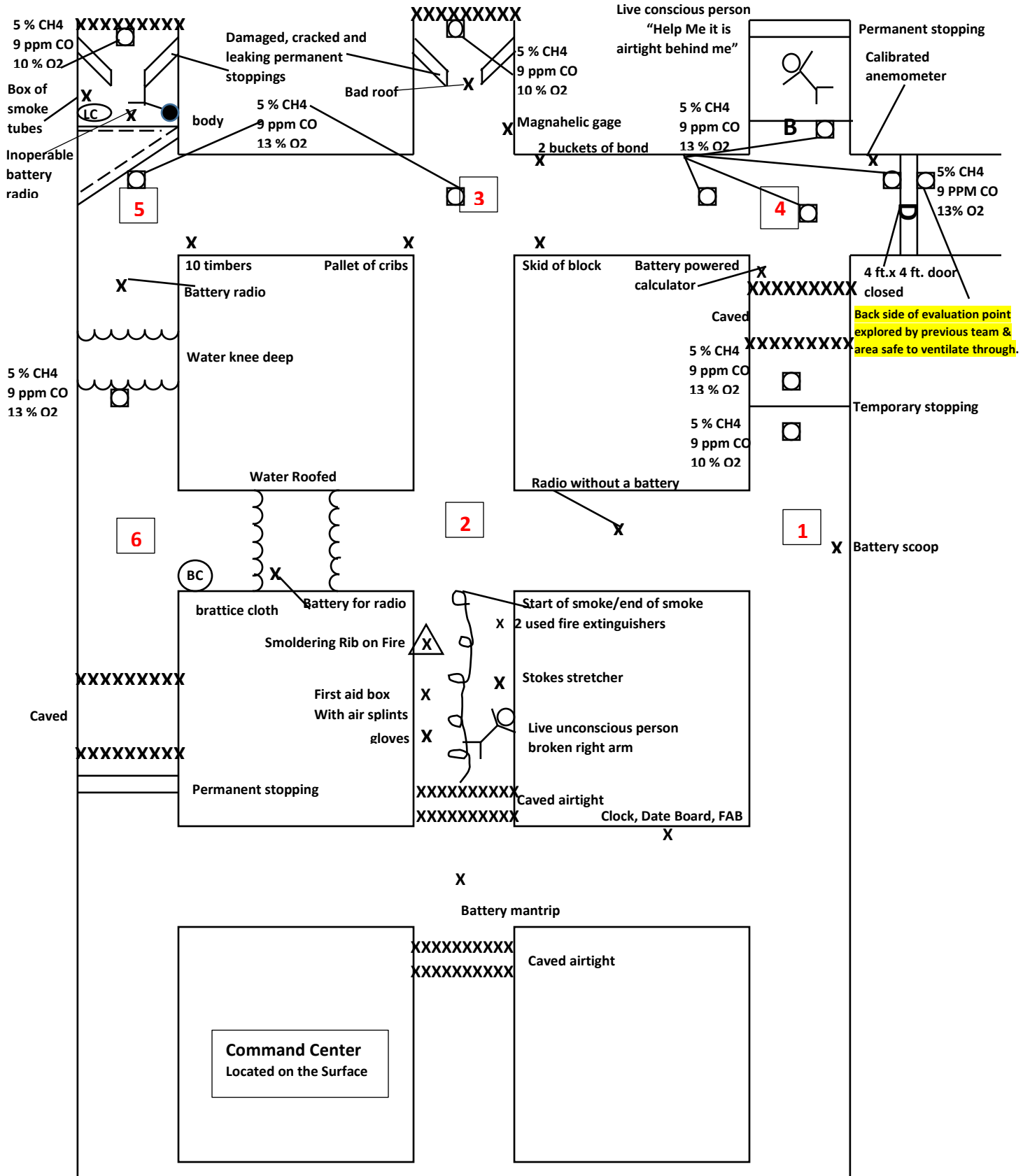

Gas Test, Roof & Rib, Date & Initials

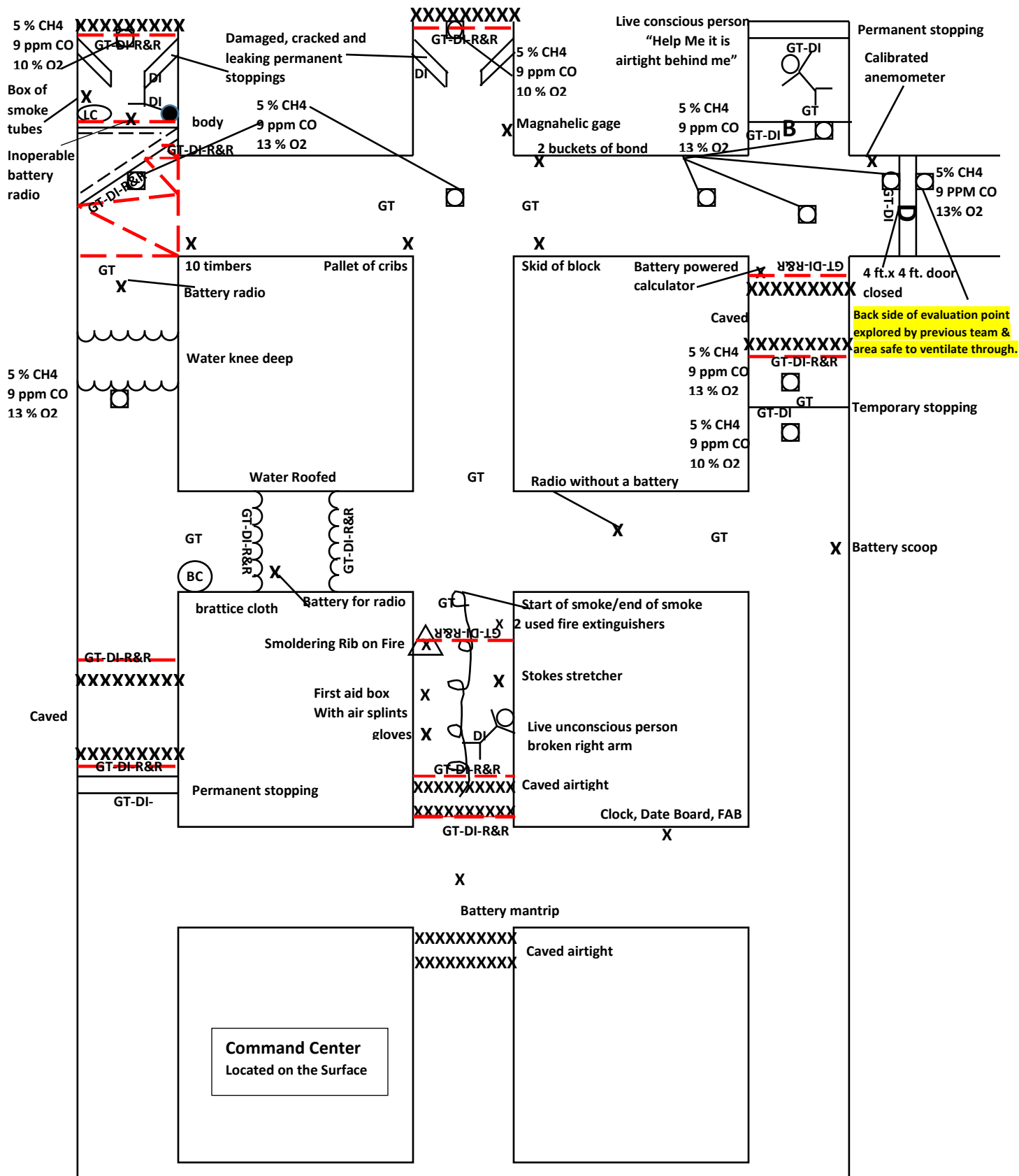

Ventilation Map

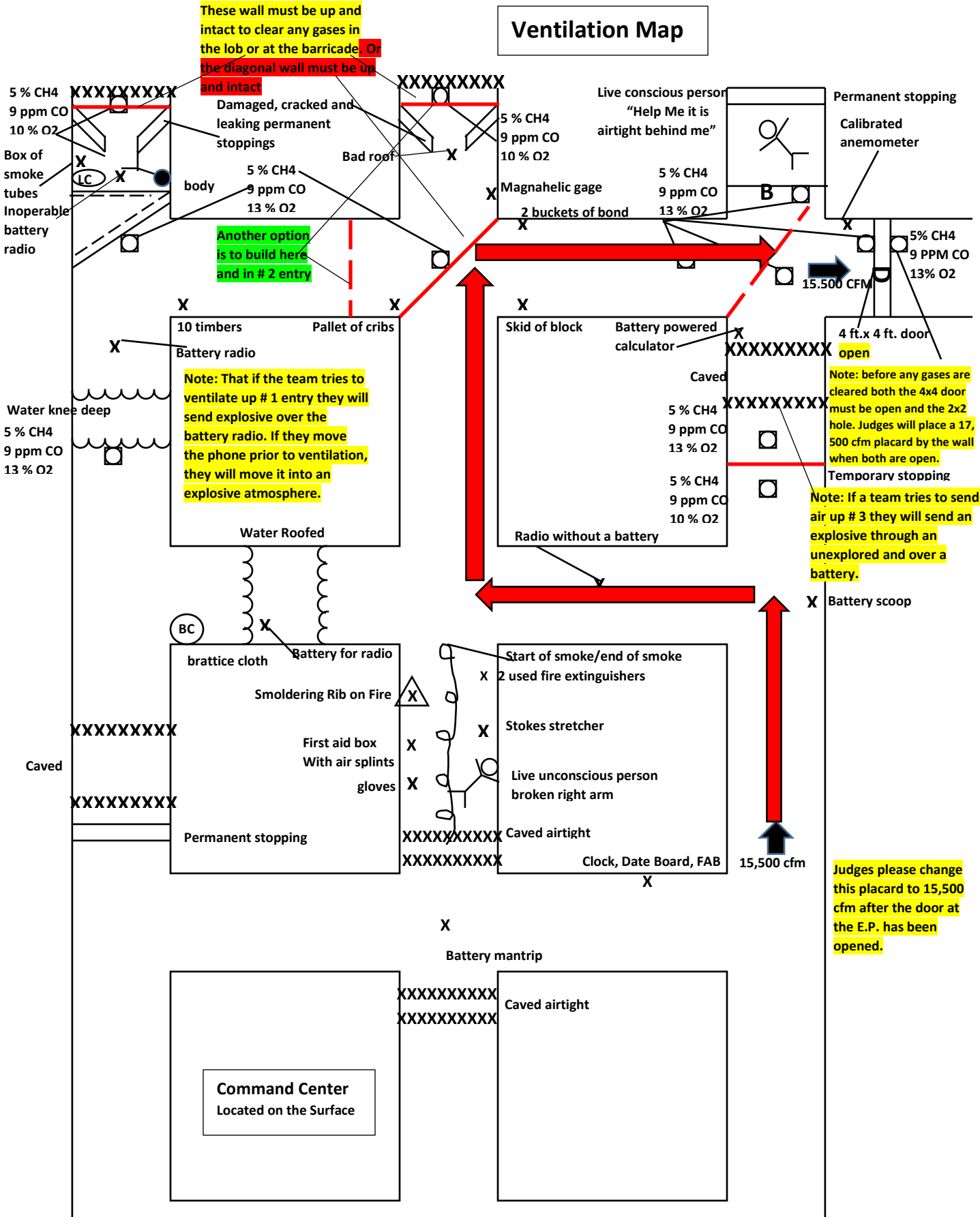

These wall must be up and intact to clear any gases in the lob or at the barricade. Or the diagonal wall must be up and intact

Another option is to build here and in # 2 entry

Note: That if the team tries to ventilate up # 1 entry they will send explosive over the battery radio. If they move the phone prior to ventilation, they will move it into an explosive atmosphere.

Note: before any gases are cleared both the 4x4 door must be open and the 2x2 hole. Judges will place a 17,500 cfm placard by the wall when both are open.

Note: If a team tries to send air up # 3 they will send an explosive through an unexploded and over a battery.

Judges please change this placard to 15,500 cfm after the door at the E.P. has been opened.

Key Points

The statement given to the team lets them know that there are 3 men missing, and a previous team had explored in the return to the evaluation point wall on the outby side. The 4 ft. X 4 ft. door was reported closed in the evaluation point wall by that team and the bottle sample the team took there was tested and showed an irrespirable and explosive gas mixture. They have also been told the return entry from that evaluation point outby to the fan is safe to ventilate through along with the exhausting fan that is currently running and cannot be stopped, stalled or reverse. They are also informed that the maps are only up to date to the walls separating the bleeder line from the pillared out works with some of those walls reported not intact and airtight.

The team is also informed that in order to clear irrespirable and explosive gases in the bleeder's last open or inby toward the pillared area a minimum of 15,000 cfm is required to pass through the last open to the return.

At team stop # 2 the team will need to tie off in air clear of smoke before any team member travels into smoke and that prior to any team member reaching or moving into smoke the entire team must be attached to their link line also. So if The captain steps into smoke on the outby side of the intersection before stopping and tying off the team is traveling in smoke. If the team stops they can enter the smoke as long as the entire team has hold of the link line also, but the 5 man must be stopped and not moving and in air clear of smoke.

At team stop 2 as the team enters the smoke the captain will encounter a fire that requires a roof and rib test, a gas test, a date and initial and extinguishing the fire before any team member travels pass the fire.

At team stop 2 in the smoke the team will find an unconscious man that will need put under oxygen before being moved, loaded onto a stretcher and carried out to the fresh air base per the instructions given to the team.

Team stop # 3, in # 2 entry of B-line, the team will find a stopping to the pillared out area down that will need re-built, the gas in the intersection is just in the intersection. The gases found going inby is not explosive but are irrespirable. The team's reach toward # 3 entry finds an explosive and contaminate gas mixtures and this determines where the team will advance toward next.

Team stop # 4 will be in B-line of # 3 entry where the team encounters a barricade inby the intersection with an explosive and irrespirable in front of it. This will require ventilation to clear the irrespirable. There is a response from the barricade the person inside

the barricade also tells the team that it is airtight behind him, but there is at this time no means to sweep the barricade or enter it. The team will also encounter the evaluation point that was mentioned in the statement, and that is shown on their maps. The 4 ft. X 4 ft. door in the wall is closed as reported in the statement that was given to the team, and shown on their maps. They also were informed by the statement the mine engineer had calculated that if the 4ft. x 4ft. door was open there would be sufficient air movement to clear gases in the last open of the bleeder line, (15,000 cfm is required). However, at this time the team does not sufficient material to course the air to accomplish that safely so they must continue to explore. Outby they will find a caved area and a battery powered calculator which is in air clear of any explosive gas. If the team moves the battery calculator, they will move it into an explosive atmosphere in the intersection.

Team stop # 5 will be in B-line of # 1 entry where there is a diagonal unsafe roof in the intersection which will require a zig zag roof and rib test in the intersection prior to the team leaving that intersection. The diagonal unsafe roof extends inby to the right rib about 2 foot and this small area requires the captain to roof and rib test here also place his date and initials and there is a gas test required there also. The team has found 10 timbers just before entering the intersection and they may decide to use these timbers to post through the unsafe roof and reach inby . The team may also make their reach outby to the imaginary line in # 1 entry find a battery radio, (that is in air clear), through the knee deep water and also encounter an explosive and irrespirable gas mixture that extends outby. If the team chooses to post through the unsafe roof before traveling outby please note how they post. Because the diagonal unsafe roof is just inby the intersection 2 foot and by rule the captain must have a solid safe rib to set his first post off of. There is not sufficient space to set a post off the right rib looking inby and allow enough room for a team member to pass between the rib and post, (see drawing below). They can set a single row and travel safely up the left rib or set a double row also to accomplish this.

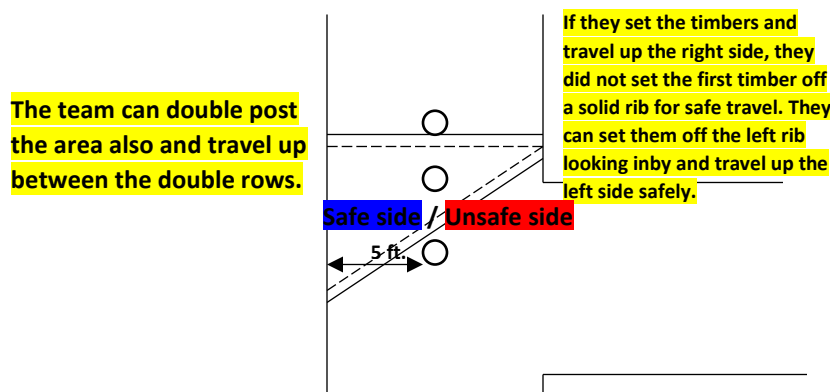

If the team has post through the unsafe roof and the captain is on the inby side he may start his roof and rib test, stop the test in order to make contact by hand and date and initial the body, continue the roof and rib test to the other rib before any team member passes through the area. As the captain makes his roof and rib test toward the rib he will find an inoperable battery radio, (the gas test breaking the intersection was clear so there is **not** a withdraw situation). The team on the inby side of the unsafe roof finds a line curtain a permanent stopping down and the caved at the old pillar line. At this time, they now have sufficient materials to ventilate the barricade, and if they do not ventilate to the barricade the team should be discounted for delay under rule 41 c. At this time from team stop # 5 the team does not need to explore outby in # 1 entry due to the information provided in the statement about area known for the map being up to date to the walls separating the pillared out area from the last open to the return. Their exploration has also found walls and a caved airtight that provides an airtight separation outby for the ventilation process.

Please note that the team may choose also to explore outby before timbering into the diagonal unsafe roof. This is allowed by the rules and if they do this team stop # 6 is in # 1 entry of A-line. Please drop down to team stop # 6 below this team stop # 5 explanation on how to ventilate.

To ventilate from team stop # 5, the team can from team stop # 5 re-build the permanent stopping that is down by the caved area toward the reported pillar line. If they already re-built the permanent stopping in #2 entry, then they can return to team stop #4 location to establish sufficient air flow. If the team chooses they may elect to take the two permanent stoppings, (see ventilation map), that are down and build a diagonal in # 2 entry where team stop # 3 was made. Note that the team does not need to explore outby in # 1 entry at this time to ventilate since the statement told them that the maps are up to date only to the walls separating the pillared out areas from the last open to the return so they should know that the outby areas of the map are known. Once the team has isolated the low oxygen and explosive gases from coming out of the old works. This will require the team to ask the superintendent for a ventilation change in writing, (**required in instructions given to the team**), since they have stopped the irrespirable air from coming out of the pillared area, and now need to open the 4 x 4 door to establish air flow. The gas placards cannot be cleared until they have achieved sufficient airflow of at least 15,000 cfm. To obtain that the team must open the 4ft.X4ft. door at the evaluation point. **Judges please place a placard down indicating the increase air flow, (if the door is open put the 15,500 cfm placard and air movement arrow placard down at the open door.** Now the team can ask in writing for an air change to sweep the barricade. Once the irrespirable has been swept from in front of the barricade the team may enter the barricade and they do not need to airlock in since the

person said it was airtight behind him. Judges please place the 15,500 cfm placard and the air movement placard in # 3 entry just inby the fresh air base before the team travels outby. **Judges please note that there are three gas placards in the last open from # 2 entry to the evaluation point that will need flipped over once the correct ventilation has been established and the correct ventilation must establish at least 15,000 cfm.** Also note that as the team travels out with the person they will need a gas test at the location of each gas placard before the entire team passes the location of the placard.

Possible team stop # 6 if the team does not timber at team stop # 5 will be in A-line of # 1 entry. At this stop the team will find a caved area heading back toward the fresh air base in the entry, and in the cross cut toward # 2 entry they will find a brattice cloth and water roofed. Now the team also has the needed materials at this point to ventilate the barricade also without timbering into the diagonal unsafe roof. **Except they do not yet have a sweep curtain, so they now must return to the area of diagonal unsafe roof and timber into it.** This information is covered in team stop # 5 above.

Once the team has brought the patient to the fresh air base. The team following the instructions given to them will require them to return to the inby area to finish exploring areas that they did not yet explore, (reference 2016 Q&A's first answer NMR Rule 44 A).

These areas should be in # 1 entry just inby the fresh air base, in # 3 entry just inby A-line, and possibly in # 1 entry outby the B-line. Areas that have an airtight wall in front of them will require air locking into by the rule # 42, and if the airlock is not used or properly maintained they will move explosive gas mixtures over ignition sources or unexplored areas and should be discounted under rule 31.