

2016 KCA Regional Mine Rescue Skills April, 7th 2016

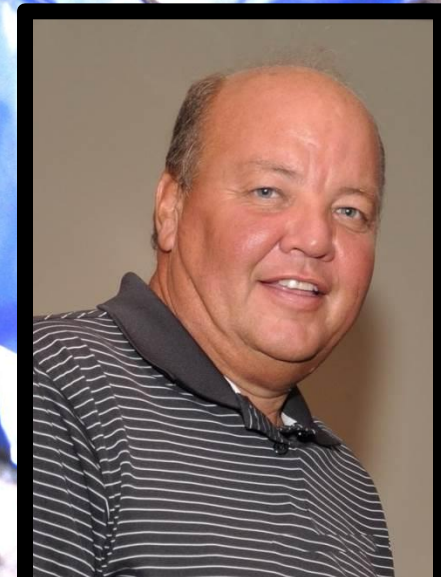

Problem Statement

You are located on the surface of the KCA #2 Mine. This is a new slope mine that is developing the main entries for a future four unit room and pillar operation.

The 3rd shift foreman sent a five man crew up to the section to timber and roof bolt areas where unsafe roof has been detected.

An explosion was heard about 2 hours ago and we tried to enter the slope but found concentrations of methane and low oxygen about halfway down the slope. The tracking system shows all 5 men are still on the section. Phone communication has been unsuccessful.

We have a blowing fan on top of an airshaft that is being used for ventilation in the no. 1 entry. The explosion must have knocked the power on the fan. The power has been restored and the fan is off at this time, but can be turned on/off by a switch located in the Command Center if needed.

There is a trained mine rescue team here to back you up and the power has been locked out and guarded. The maps were up to date as of yesterday.

Please be careful and find our miners.

2016 KCA Skills

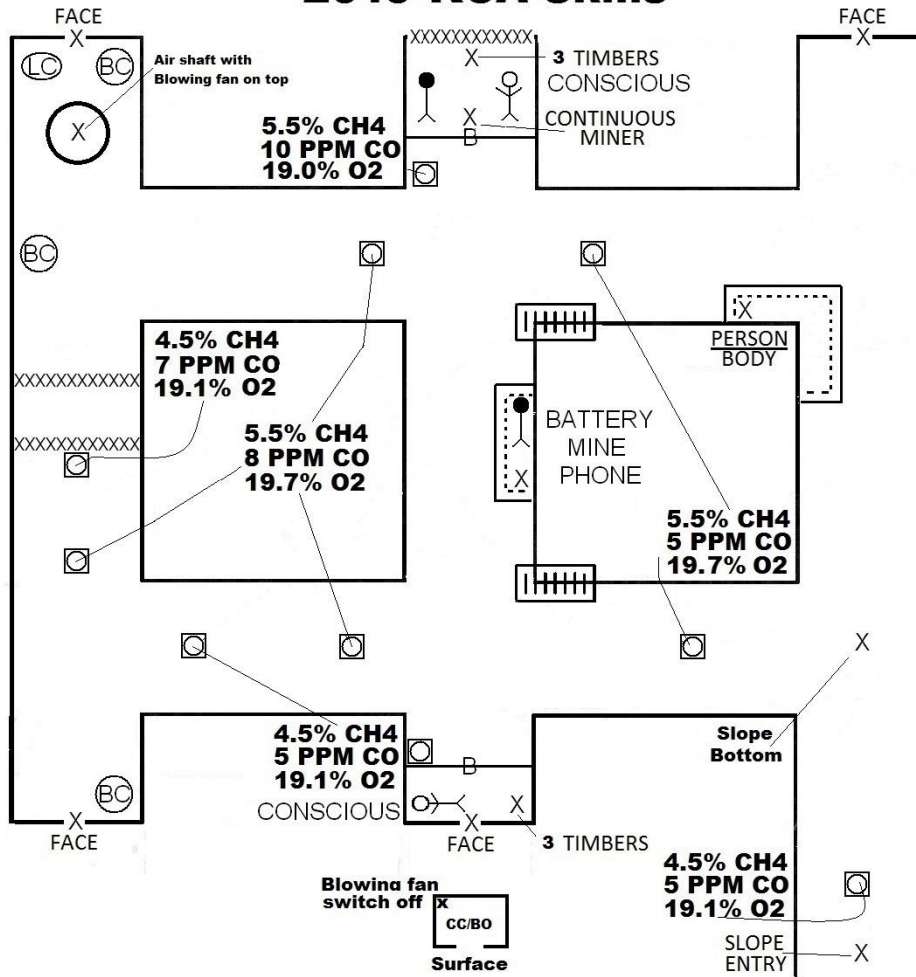

2016 KCA Regional Skills Contest

Written Instructions

ACCOUNT FOR ALL MISSING MINERS

THE BLOWING FAN CANNOT BE REVERSED

**THE BRIEFING OFFICER/COMMAND CENTER HAS
BEEN ESTABLISHED ON THE SURFACE**

Patient Statement behind Barricade in first open
crosscut

**Help! Get me out. It's
airtight behind me!**

Patient Statement behind Barricade in last open
crosscut

**Help! Get me and Buford
out !**

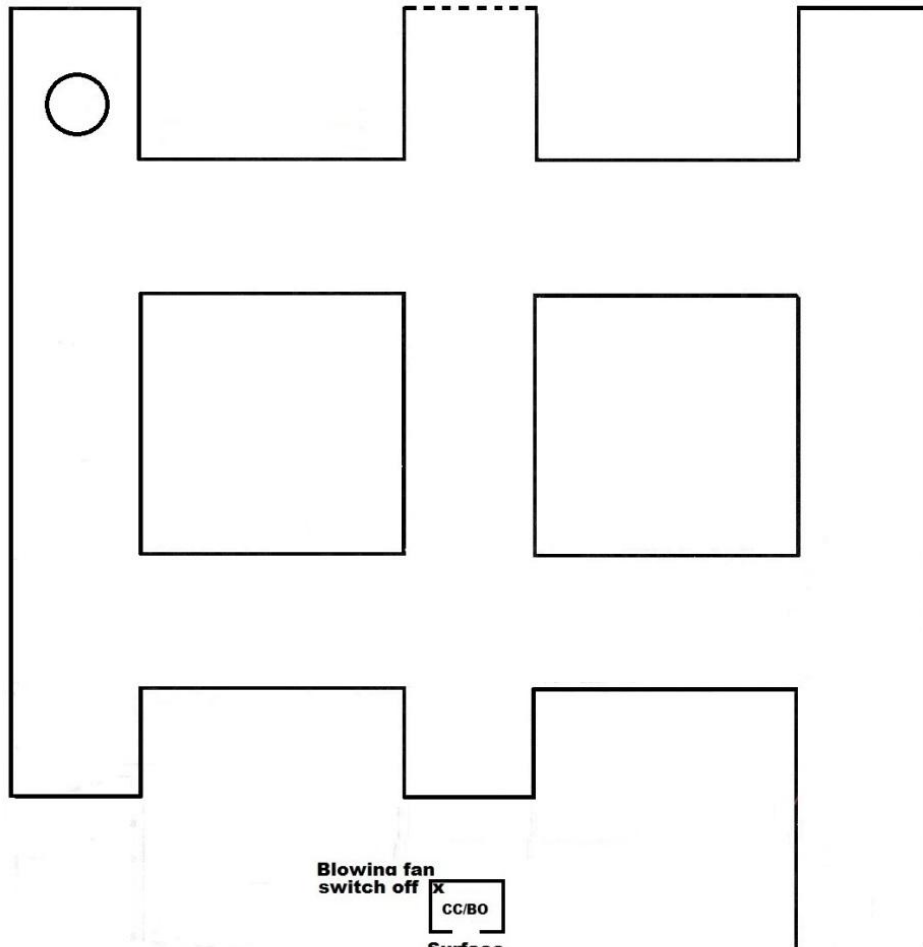

Team Stops
Gas tests, Date & Int. Roof & Rib test

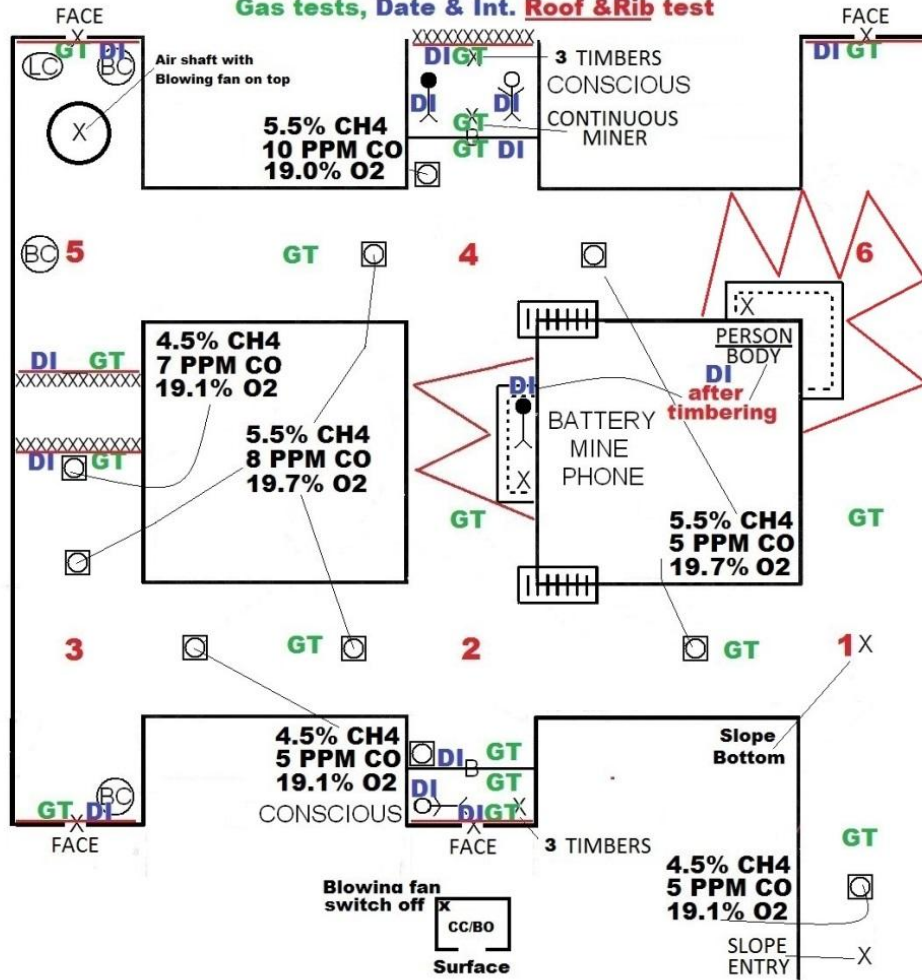

Irrespirable // Explosive

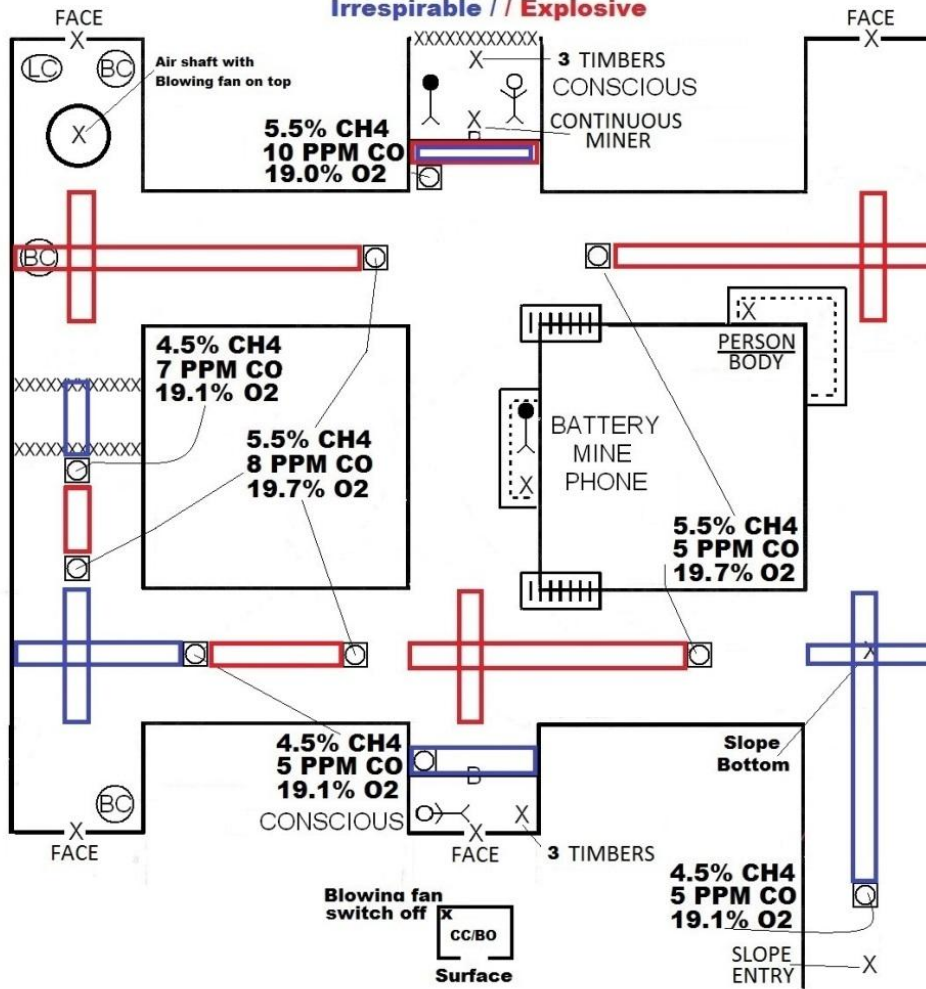

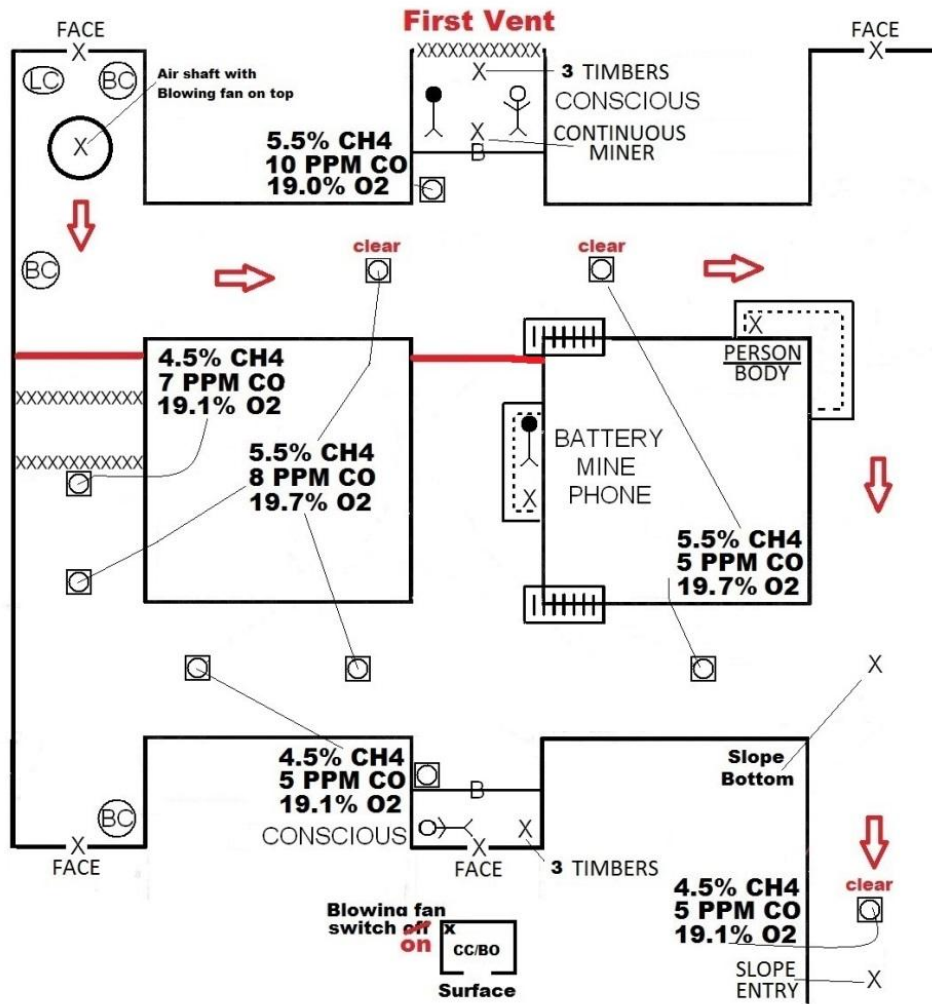

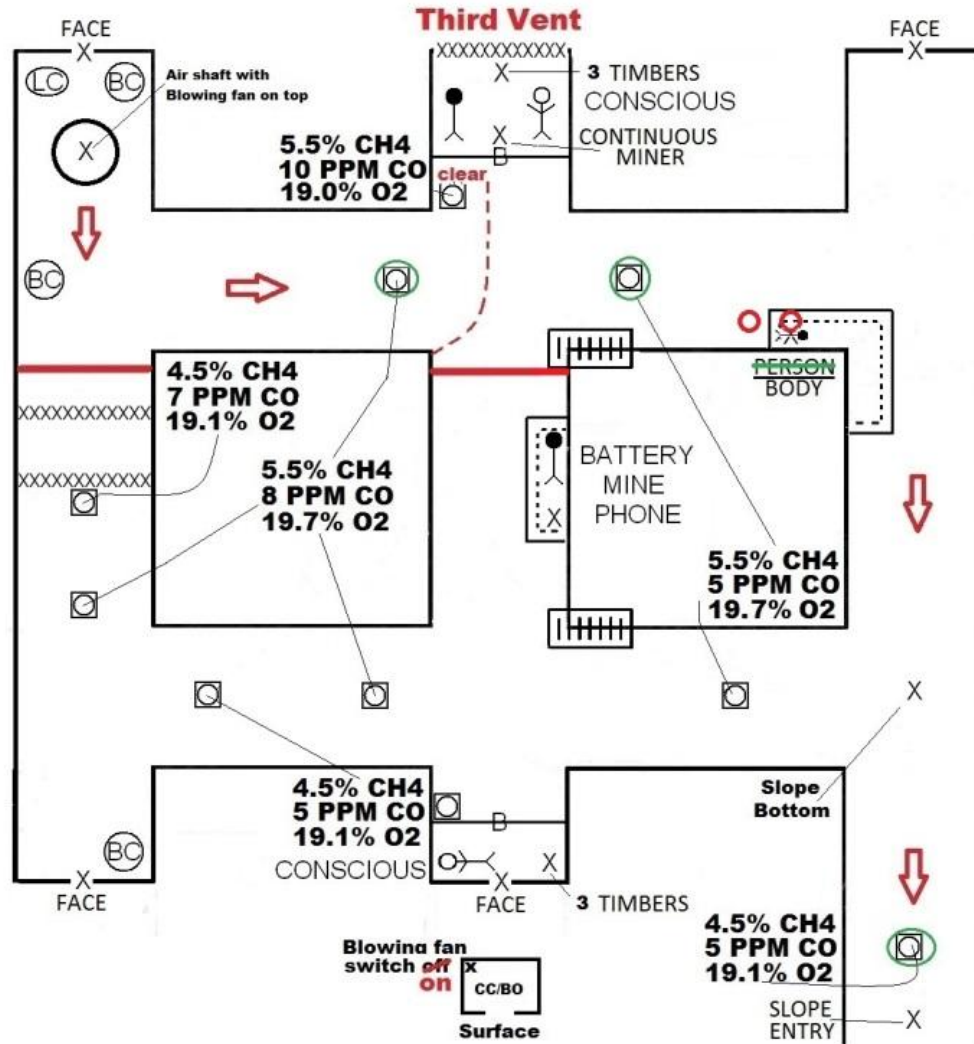

Keys to Problem

- **Team must enter the mine in the # 3 entry (Slope)**
- **The blowing fan is in by the FAB, so air will migrate in the mines when fan is on.**
- **Team must not let explosive mixtures flow over battery mine phone and caved areas**
- **Team must not let irrespirable atmospheres flow over person in unsafe roof**
- **Team cannot wing either barricade from unsafe rib corner side**
- **Team must timber to person before rescuing conscious live person behind barricade in last open crosscut**
- **Team must timber to body before stopping the clock**