

2015 Tri State Post No. 6 Bio-Pak 240 R Bench Contest



STATEMENT TO BENCH CONTESTANT

The bench participant will be provided with two Bio-Pak 240- R apparatus (one disassembled, one assembled), a stopwatch, defogging solution, leak detector fluid, test kit, and tool kit. Only the tools and fluid provided will be used for testing and assembly of the apparatus. The work at the bench will consist of:

1. A visual examination of a disassembled Bio-Pak 240-R and the proper assembly and preparation for use in rescue work. This will include correcting any predetermined problem(s) so that the apparatus is in proper working order. Simulating defogging of the facepiece lens will be done as a part of the visual examination. This visual examination, correcting predetermined problem(s), and proper assembly can be done at any time allowed for the working of the problem.
2. Test the assembled Bio-Pak 240-R apparatus with a tester, and correct the predetermined problem(s) so that the apparatus is in proper working condition. Except for removing the facepiece storage plug on the breathing hoses, the assembled Bio-Pak 240-R apparatus cannot be disassembled to look for problems, until the Flow Test is started. When testing is completed on the assembled Bio-Pak 240-R apparatus, the hoses shall be removed from the tester, connected to the facepiece, and the upper housing installed. This shall be done before the clock is stopped.

When an unplanned deficiency is encountered in the apparatus, the participant will be notified by the judge(s) that the deficiency is not part of the problem. The judge will stop the clock and any time used to correct the deficiency will not be charged to the working time.

A maximum of 30 minutes will be allowed to complete the problem. The judge will tell you when 29 minutes has passed. At the completion of the problem, the judge(s) and the participant will note the working time of the problem with the official timekeeper. Work done after the clock is stopped will not be recognized.

Table Layout for Bio-Pak 240-R Contest

<p>Test Apparatus With Upper Housing And Hose Connector Installed</p>	<p>Test Apparatus Mask</p>	<p>Upper Housing With Parts</p>	<p>Visual Apparatus</p>
	<p>Test Kit</p>		

BIO-PAK 240-R VISUAL APPARATUS (BREAK DOWN)

Upper Housing Assembly-Removed
Hoses-Removed
Coolant Lids and Ice Canisters - Removed
Center Section Lid Assembly - Removed
Moisture Pads - Removed
Carbon Dioxide Scrubbers and Gasket - Removed
PCM Canister - Removed
Loosen (But do not remove) Flow Restrictor
Center Section – Removed
Diaphragm and worm gear-Removed
Vent Valve Assembly - Removed as a unit
Oxygen Cylinder-Removed

BIO-PAK 240-R TOOL KIT

Leak Check Adapter Fitting
Flow Test Fixture
Test Key
Vent Valve Hand Wrench
Center Section Pneumatic Plug
Regulator Wash Cover
Combination Pick Tool
#00 Phillips Head Screwdriver
#1 Phillips Head Screwdriver
#2 Phillips Head Screwdriver
1/4" Hex Driver
3/16" Nut Driver
5/16" Nut Driver
9/32" Nut Driver
3/8" x 5/16" Open End Wrench
7/16" Combination Wrench
1/2" Combination Wrench
5/8" x 9/16" Open End Wrench
Stop Watch
Bypass Valve Tool

**Tri-State Post No. 6
Ohio Valley Mine Recue Contest
Bio-Pak 240R Bench Problem 2015**

Visuals

- 1. Speech Diaphragm in Backwards**
- 2. Oxygen Cylinder Seal Missing (Provide Seal)**
- 3. Center Section O-Ring Missing (Provide O-Ring)**

Tester

- 1. Misplaced Vent Seat O-Ring (Low Pressure Leak/Demand Flutter)**
- 2. Missing Demand Add O-Ring (High pressure Leak)
Provide O-Ring**
- 3. Missing Flow Restrictor O-Ring (Abnormal high Flow Rate)
Provide Complete Assembly**

Post 6 Mine Rescue Contest
240R Visual Apparatus
Problem Design

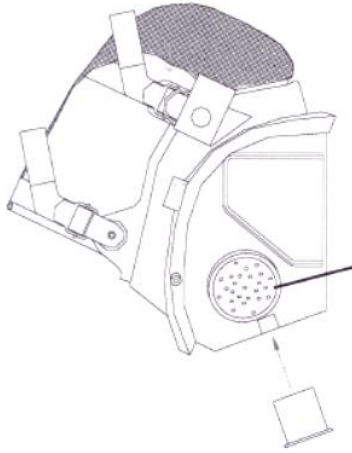

Speech Diaphragm in Backwards
(Identify Only)

Oxygen Cylinder Seal Missing
(Provide Seal)

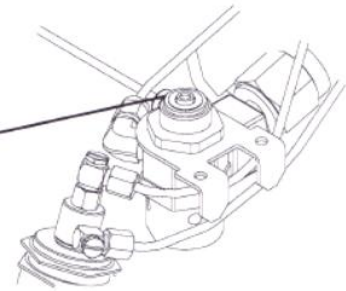

Center Section O-ring Missing
(Provide O-ring)

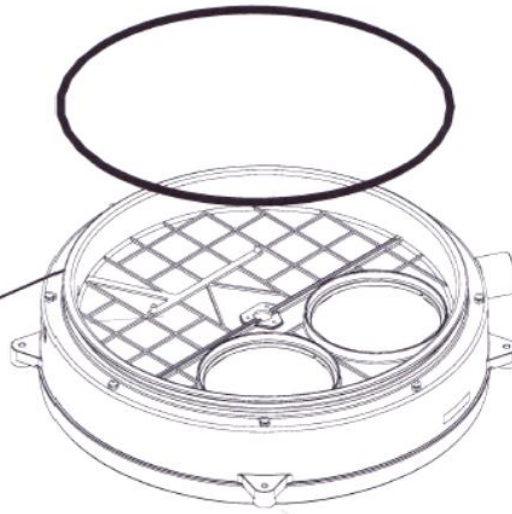

Post 6 Mine Rescue Contest 240R Test Apparatus Problem Design

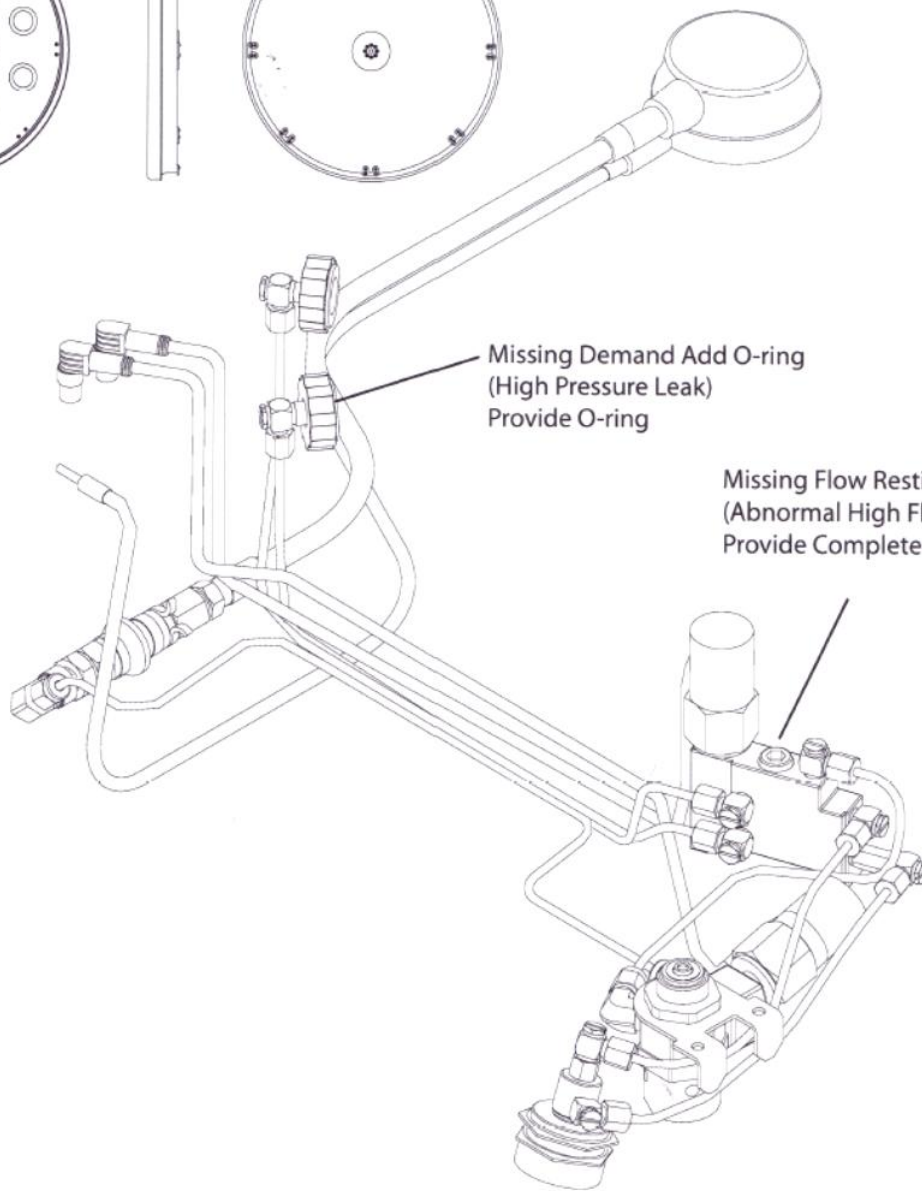
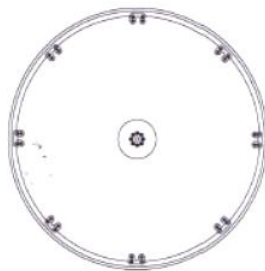
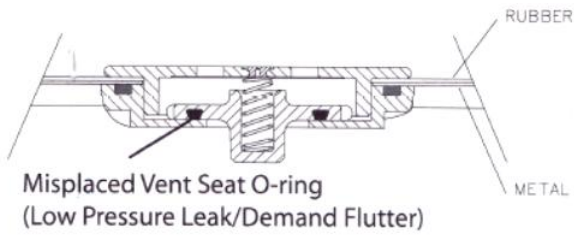

BIOPAK 240R BENCH CONTESTANT _____ WORKING TIME _____ MIN. _____ SEC.

VISUAL APPARATUS CHECKS		TEST APPARATUS	
✓	Check if ok		CONNECTIONS
	UPPER HOUSING		- Vent Valve Assembly - Hand Tight
	LOWER HOUSING		- Diaphragm Worm Gear - Wrench Tight
	- Harness Assembly		- Flow Restrictor - Wrench Tight
	- External Gage		- Breathing Hose Worm Gear - Wrench Tight
	- O ₂ Regulator / Seal		- Add / Constant Fittings – Hand Tight
	- RMS		Center Section Lid - Hand Tight
	CENTER SECTION ASSEMBLY		- Center Section Push Pins - Hand Tight
	- Diaphragm		- Cylinder Connection - Hand Tight
	- O-Ring and Sealing Edges		- Adapter to Facepiece - Hand Tight
	Demand Valve Assembly		- Test Fixture Connections - Hand Tight
	Moisture Pads	✓	Check if ok
	PCM		CONSTANT FLOW TEST
	CARBON DIOXIDE SCRUBBER		Flow Between 1.6 and 2.4 Lpm - State Reading
	- Defects / Damage		DEMAND VALVE TEST
	- Gasket		EMERGENCY BYPASS TEST
	- Expiration Date		VENT VALVE TEST
	CENTER SECTION LID ASSEMBLY		At or below 2 inches wg - State Reading
	- Examine for defects / damage		LOW PRESSURE LEAK TEST
	- Check O-Ring for damage / lubrication		RMS GAUGE AND TRIM TEST
	Ice Canisters		Observe lights/gauges +/- 10% - State Reading
	Coolant Lids		HIGH PRESSURE LEAK TEST
	CYLINDER TEST		LOW PRESSURE ALARM TEST
	- Hydrostatic Test Date		Alarm 650-1000 psig – State Reading
	- Cylinder Pressure on Gauge		Power down below 25 psig
	- Pressure Rating on Cylinder	VI	C Visual Apparatus
	HOSES		Speech Diaphragm in Backwards (Identify only)
	- Sealing Edges		Oxygen Cylinder Seal missing (Provide Seal)
	- Stretching of Hoses for Pliability		Center Section O-Ring Missing(Provide O-Ring)
	Adapter Assembly / Gasket		
	FACE PIECE TEST		
	- Head Strap Assembly	VI	C TESTER
	- Mask Body / Nose Cup		Misplaced Vent Seat O-Ring(Low Pressure Leak/Demand Flutter)
	- Sealing Edges		Missing Demand Add O-Ring (High Pressure Leak)Provide O-Ring
	- Speech Diaphragms		Missing Flow Restrictor O-Ring (Abnormal High Flow Rate) Provide Complete Assembly
	- Lens / Anti-Fog Insert		
	- Defog Mask (Simulate)		

BIOPAK 240R BENCH CONTESTANT _____ WORKING TIME _____ MIN. _____ SEC.

VISUAL APPARATUS CHECKS		TEST APPARATUS	
✓	<i>Check if ok</i>		CONNECTIONS
	UPPER HOUSING		- Vent Valve Assembly - Hand Tight
	LOWER HOUSING		- Diaphragm Worm Gear - Wrench Tight
	- Harness Assembly		- Flow Restrictor - Wrench Tight
	- External Gage		- Breathing Hose Worm Gear - Wrench Tight
	- O2 Regulator / Seal		- Add / Constant Fittings - Hand Tight
	- RMS		Center Section Lid - Hand Tight
	CENTER SECTION ASSEMBLY		- Center Section Push Pins - Hand Tight
	- Diaphragm		- Cylinder Connection - Hand Tight
	- O-Ring and Sealing Edges		- Adapter to Facepiece - Hand Tight
	- Demand Valve Assembly		- Test Fixture Connections - Hand Tight
	- Moisture Pads	✓	<i>Check if ok</i>
	- PCM		CONSTANT FLOW TEST
	CARBON DIOXIDE SCRUBBER		Flow Between 1.6 and 2.4 Lpm - State Reading
	- Defects / Damage		DEMAND VALVE TEST
	- Gasket		EMERGENCY BYPASS TEST
	- Expiration Date		VENT VALVE TEST
	CENTER SECTION LID ASSEMBLY		At or below 2 inches wg - State Reading
	- Examine for defects / damage		LOW PRESSURE LEAK TEST
	- Check O-Ring for damage / lubrication		RMS GAUGE AND TRIM TEST
	- Ice Canisters		Observe lights/gauges +/- 10% - State Reading
	- Coolant Lids		HIGH PRESSURE LEAK TEST
	CYLINDER TEST		LOW PRESSURE ALARM TEST
	- Hydrostatic Test Date		Alarm 650-1000 psig - State Reading
	- Cylinder Pressure on Gauge		Power down below 25 psig
	- Pressure Rating on Cylinder	VI	C
	HOSES		Visual Apparatus
	- Sealing Edges		Speech Diaphragm in Backwards (Identify only) Oxygen Cylinder Seal missing (Provide Seal)
	- Stretching of Hoses for Pliability		Center Section O-Ring Missing (Provide O-Ring)
	- Adapter Assembly / Gasket		
	FACE PIECE TEST		
	- Head Strap Assembly	VI	C
	- Mask Body / Nose Cup		TESTER
	- Sealing Edges		Misplaced Vent Seat O-Ring (Low Pressure Leak/Demand Flutter)
	- Speech Diaphragms		Missing Demand Add O-Ring (High Pressure Leak) Provide O-Ring
	- Lens / Anti-Fog Insert		Missing Flow Restrictor O-Ring (Abnormal High Flow Rate) Provide Complete Assembly
	- Defog Mask (Simulate)		

BIOPAK 240R BENCH CONTESTANT _____ WORKING TIME _____ MIN. _____ SEC.

VISUAL APPARATUS CHECKS		TEST APPARATUS	
✓	Check if ok		CONNECTIONS
	UPPER HOUSING		- Vent Valve Assembly - Hand Tight
	LOWER HOUSING		- Diaphragm Worm Gear - Wrench Tight
	- Harness Assembly		- Flow Restrictor - Wrench Tight
	- External Gage		- Breathing Hose Worm Gear - Wrench Tight
	- O2 Regulator / Seal		- Add / Constant Fittings – Hand Tight
	- RMS		Center Section Lid - Hand Tight
	CENTER SECTION ASSEMBLY		- Center Section Push Pins - Hand Tight
	- Diaphragm		- Cylinder Connection - Hand Tight
	- O-Ring and Sealing Edges		- Adapter to Facepiece - Hand Tight
	- Demand Valve Assembly		- Test Fixture Connections - Hand Tight
	- Moisture Pads	✓	Check if ok
	- PCM		CONSTANT FLOW TEST
	CARBON DIOXIDE SCRUBBER		Flow Between 1.6 and 2.4 Lpm - State Reading
	- Defects / Damage		DEMAND VALVE TEST
	- Gasket		EMERGENCY BYPASS TEST
	- Expiration Date		VENT VALVE TEST
	CENTER SECTION LID ASSEMBLY		At or below 2 inches wg - State Reading
	- Examine for defects / damage		LOW PRESSURE LEAK TEST
	- Check O-Ring for damage / lubrication		RMS GAUGE AND TRIM TEST
	- Ice Canisters		Observe lights/gauges +/- 10% - State Reading
	- Coolant Lids		HIGH PRESSURE LEAK TEST
	CYLINDER TEST		LOW PRESSURE ALARM TEST
	- Hydrostatic Test Date		Alarm 650-1000 psig – State Reading
	- Cylinder Pressure on Gauge		Power down below 25 psig
	- Pressure Rating on Cylinder	VI	C
	HOSES		Visual Apparatus
	- Sealing Edges		Speech Diaphragm in Backwards (Identify only) Oxygen Cylinder Seal missing (Provide Seal)
	- Stretching of Hoses for Pliability		Center Section O-Ring Missing (Provide O-Ring)
	- Adapter Assembly / Gasket		
	FACE PIECE TEST		
	- Head Strap Assembly	VI	C
	- Mask Body / Nose Cup		TESTER
	- Sealing Edges		Misplaced Vent Seat O-Ring (Low Pressure Leak/Demand Flutter)
	- Speech Diaphragms		Missing Demand Add O-Ring (High Pressure Leak) Provide O-Ring
	- Lens / Anti-Fog Insert		Missing Flow Restrictor O-Ring (Abnormal High Flow Rate) Provide Complete Assembly
	- Defog Mask (Simulate)		